

FM 22-6

FIELD MANUAL

GUARD DUTY

This copy is a reprint which includes current pages from Change 1.

HEADQUARTERS, DEPARTMENT OF THE ARMY

SEPTEMBER 1971

CHANGE } HEADQUARTERS
NO. 1 } DEPARTMENT OF THE ARMY
WASHINGTON, D.C., 15 January 1975

GUARD DUTY

FM 22-6, 17 September 1971, is changed as follows:

Page 2-2. Paragraph 4i. Line 1 is changed to read:

"i. Guard, Sentinel, Sentry. A term used . . ."

Page 2-2. Paragraph 4i subparagraphs 4i (2) "(a)" and "(b)" are deleted.

Page 2-3. Paragraph 4p (1). In lines 2 and 3 the following is deleted: "It is disseminated only to friendly personnel."

Page 2-4. Paragraph 4p (2). Lines 2-5 are changed to read as follows: "The second word or part of the countersign, and it is used in answer to the challenge."

Page 4-2. Paragraph 10a. In line 1 "*anything*" is changed to read "*everything*."

Page 6-2. Paragraph 35a. In line 1 of the Note "to" is changed to read "in."

Page 6-3. Paragraph 35b. In line 8 "platoon" is changed to read "guard."

Page 6-3. Paragraph 36a. In line 10 "says" is changed to read "reports."

Page 6-6. Paragraph 39*b*. In line 7 “platoon” is changed to read “squad.”

Page 6-16. Paragraph 48*a*. In line 7 “command” is changed to read “commander.”

Page 6-17. Paragraph 49*a*. In line 1 “no” is changed to read “on.”

Page 6-21. Paragraph 50*b*. In line 8 “half” is changed to read “halt.”

Page 6-22. Paragraph 50*b*(1). In line 2 “TANSMIT” is changed to read “TRANSMIT.”

Page 6-22. Paragraph 50*b*(1). In line 8 “he” is changed to read “the.”

Page 6-22. Paragraph 50*b*(2). In line 4 “command” is changed to read “commander.”

Page 6-22. Paragraph 50*d*. In line 2 “squad” is changed to read “guard.”

Page 6-36. Paragraph 65*a*. In line 22 “paces” is changed to read “steps.”

Page 6-39. Paragraph 65*e* (1). In line 3 “of” is deleted.

Page 7-1. Paragraph 70*a*. Line 2 is changed to read: “. . . of the park guard absent themselves from . . .”

By Order of the Secretary of the Army:

FRED C. WEYAND

General, United States Army

Official:

Chief of Staff

VERNE L. BOWERS

Major General, United States Army

The Adjutant General

Distribution:

Active Army, ARNG, USAR: To be distributed in accordance with DA Form 12-11A requirements for Guard Duty (Qty rqr block no. 179).

FIELD MANUAL } HEADQUARTERS
 No. 22-6 } DEPARTMENT OF THE ARMY
 WASHINGTON, D. C., 17 September 1971

GUARD DUTY

		Paragraph	Page
PART ONE. INTRODUCTION			
CHAPTER 1.	GENERAL -----	1, 2	1-1
	2. TERMINOLOGY -----	3, 4	2-1
	3. GUARD COMPOSITION -----	5-7	3-1
PART TWO. INTERIOR GUARD			
CHAPTER 4.	ORDERS -----	8-12	4-1
	5. MAIN GUARD		
	Section I. General -----	13-15	5-1
	II. Duties of personnel -----	16-23	5-2
	III. Patrol system -----	24-27	5-11
	IV. Fixed post system -----	28-30	5-12
CHAPTER 6.	GUARD MOUNTING		
	Section I. General -----	31, 32	6-1
	II. Guard mount (inspection only) -----	33-36	6-1
	III. Informal guard mounting -----	37-43	6-5
	IV. Relieving the old guard -----	44-48	6-12
	V. Posting reliefs -----	49-51	6-17
	VI. Formal guard mounting -----	52-66	6-26
CHAPTER 7.	SPECIAL GUARDS		
	Section I. General -----	67, 68	7-1
	II. Park guards -----	69-73	7-1
	III. Other special guards -----	74-76	7-4
PART THREE. EXTERIOR GUARD			
CHAPTER 8.	FUNCTIONS OF THE EXTERIOR GUARD -----	77-86	8-1
	9. COUNTERSIGNS AND PAROLE WORDS -----	87-92	9-1

* This manual supersedes FM 22-6, 1 May 1967.

	Page
APPENDIX A. REFERENCES	A-1
B. DETAILS AND ROSTERS ...	B-1
C. LEGEND OF SYMBOLS	C-1
D. SAFETY REGULATIONS ...	D-1
E. PRISONERS AND PRISONER GUARDS	E-1
F. DETAILS OF AGREEMENT FROM STANAG NO. 2042 (2D EDITION) AND CENTO STANAG NO. 2042	F-1
INDEX	Index 1

PART ONE

INTRODUCTION

CHAPTER 1

GENERAL

1. Purpose and Scope

a. This manual is for personnel concerned with the organization and functions of interior and exterior guard. It includes orders, countersigns, parole words, and responsibility of the main guard including duties of personnel and methods of mounting the guard. The manual also discusses the duties and composition of special guards.

b. As this manual is a guide, and as all possible situations and eventualities cannot be foreseen or covered by the manual, great reliance must be placed upon the application of sound judgment and common sense by all members of a guard and by all security personnel. In situations not covered by this manual and where doubt arises as to the proper action to be taken, the individual must consider his mission and apply sound judgment in making the required decision(s).

c. The material in this manual is applicable to both nonnuclear and nuclear warfare.

2. Comments

Users of this publication are encouraged to submit recommended changes or comments to improve the publication. Comments should be keyed to the specific page, paragraph, and line of text in which the change is recommended. Reasons will be provided for each comment to insure understanding and complete evaluation. Comments should be prepared using DA Form 2028 (Recommended Changes to Publications) and forwarded direct to the Commandant, US Army Infantry School, Fort Benning, GA 31905.

CHAPTER 2

TERMINOLOGY

3. General

The terminology relative to guard duty is listed below. This list points out words and phrases which have a particular meaning in this manual.

4. Terms

a. Commanding Officer. The officer commanding an installation, organization, unit, garrison, or bivouac.

b. Field Officer of the Day. A field grade officer detailed as the personal representative of the commanding officer. During his tour of duty he is responsible to the commanding officer for the security of the installation or activity and other duties as may be assigned depending upon local directives.

c. Officer of the Day. An officer, acting directly under the commanding officer or field officer of the day, who is responsible on a given day for the execution of all orders of the commanding officer relating to guard duty and other duties as may be assigned.

d. Commander of the Guard. The senior officer or noncommissioned officer of the guard, next junior to the officer of the day. He is responsible for the instruction, discipline, and performance of duty of the guard.

e. Sergeant of the Guard. The senior noncommissioned officer of the guard. He supervises the enlisted members of the guard and is responsible to the commander of the guard.

f. Relief Commander(s). The next senior noncommissioned officer(s) of the guard.

g. Main Guard. Regular interior guard of a post or unit whose principal duties are to patrol the area and protect the personnel, buildings, and equipment. A main guard is a subdivision of the interior guard of a command. Other subdivisions include escort guard or honor guards, for example.

h. Fixed Post System. Assigning sentinels to guard duty at fixed posts where they remain until relieved.

i. Guard. A term used when referring to—

(1) A special unit responsible to the officer of the day for the protection and security of an installation or area. This unit includes a commander of the guard, sergeant of the guard, commanders of the relief, and the guards.

(2) An individual responsible to keep watch over, protect, shield, defend, warn, or any duties prescribed by general orders and/or special orders. Also referred to as a sentinel, sentry, or lookout.

(a) Sentinel. An individual of the guard whose duties are prescribed by general and/or special orders. Also referred to as a guard, sentry, or lookout.

(b) Sentry. A guard, sentinel, or lookout.

j. Guard's Post. An area for which the guard is responsible. Within his post, a guard performs the duties required by general and special orders.

k. Supernumerary. An extra member of the guard who is used when needed to replace a guard or perform duties prescribed by local directives.

l. Guardhouse. A building, tent, or other location occupied by men detailed for interior guard duty. It is the headquarters for the guard.

m. Correctional Officer. The correctional officer, appointed by the commanding officer of a military installation, is charged with the custody, administration, and treatment of prisoners.

n. Stockade. A correctional facility, under the jurisdiction of an installation commander, used for the confinement of military prisoners.

o. Challenge (app F). Any process carried out by one unit or person with the object of ascertaining the friendly or hostile character or identity of another. The command "HALT, WHO IS THERE?" is used to cause an unidentified party or person to halt and be identified. If an additional *challenge* is used, it follows the original challenge and consists of a word or distinctive sound disseminated only to friendly or authorized persons.

p. Countersign (app F). A countersign consists of two words: the secret challenge and its password. The words comprising the countersign are issued from the principal headquarters of a command to aid guards in their scrutiny of persons who apply to pass (chap 9). These words are disseminated only to friendly personnel.

(1) *Challenge.* The first word or part of the countersign, used to challenge a person or party. It is disseminated only to friendly personnel.

(2) *Password.* A secret word or distinctive

sound used to reply to a challenge. The second word or part of the countersign. It is used in answer the challenge and is disseminated only to friendly personnel.

(3) *Parole*. A *special password* used as a check on the countersign. For a more complete explanation, refer to chapter 9.

CHAPTER 3

GUARD COMPOSITION

5. General

The guard may be one of two types, interior guard (part two) or exterior guard (part three).

6. Interior Guard

An *interior guard* is detailed by commanders of military installations to protect property and enforce specific military regulations. The installation commander is responsible for the interior guard of the installation and he prescribes the composition of the guard. When brigades and separate units are responsible for an interior guard within their own areas, their composition, duties, and responsibilities are similar to those outlined in this manual. Commanders of units furnishing personnel for guard are responsible to insure that these men are qualified or familiar with the weapon they use on guard. The elements of an interior guard are classified according to their purpose. They include the main guard and special guards. The main guard consists of a combination of patrols and fixed posts. Special guards are used, to protect parks, trains, boats, aircraft, and for other special purposes (fig 1).

7. Exterior Guard

This is a term used in this manual to differentiate from interior guard. Exterior guards are those guards whose duties and responsibilities are different from those set down for interior guards. Exterior guard is not as formal and restricted as interior guard. Classified as exterior guards are lookouts, listening posts, outposts, specifically designated patrols, and other guards in combat zones, field training areas, and guards outside the limits of a military installation. Exterior guards perform their duties as prescribed by special orders and instructions.

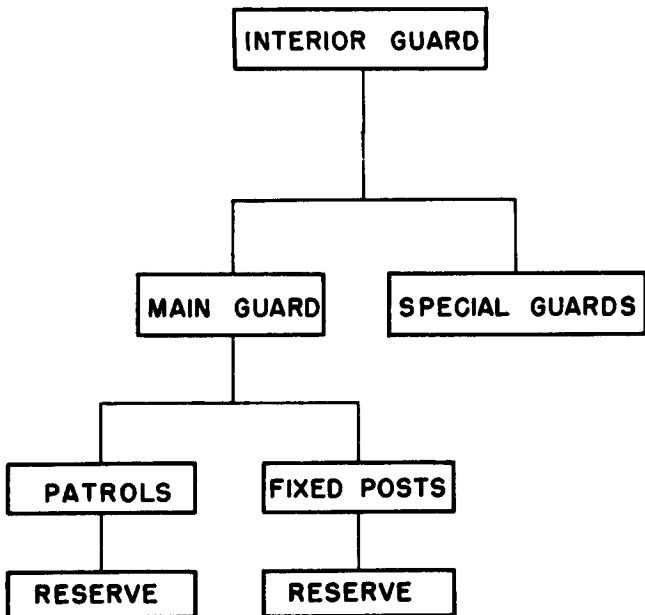

Figure 1. General breakdown of interior guard.

PART TWO
INTERIOR GUARD
CHAPTER 4
ORDERS

8. Classes of Orders

A guard on post is governed by two types of orders: general orders and special orders. General orders outline the fundamental responsibilities of a guard while special orders instruct him in the actual performance of his duty while on a particular post. General orders for both interior and exterior guards must be supplemented by realistic, detailed, and mission-oriented special orders carefully tailored for the specific post and situation from the viewpoint of security and sentry effectiveness and protection. The special orders for each post must be reviewed frequently to insure they do not become obsolete. A special order may be added to a guard post for a specific length of time to cover a certain situation and deleted at the end of a specified time, or on a certain date.

9. General Orders

All interior guards are required to memorize, understand, and comply with the following general orders:

a. Number 1. I will guard everything within the

limits of my post and quit my post only when properly relieved.

b. Number 2. I will obey my special orders and perform all my duties in a military manner.

c. Number 3. I will report violations of my special orders, emergencies, and anything not covered in my instruction, to the commander of the relief.

10. Meaning of the General Orders

a. Number 1. I will guard anything within the limits of my post and quit my post only when properly relieved.

(1) The guard is responsible for everything that occurs within the limits of his post while he is on duty. He is also responsible for all equipment and property located within the limits of his post. The exact limits of his post are defined by special orders. The special orders should also include every place a guard must go to perform his duties.

(2) A guard investigates immediately every unusual or suspicious occurrence on or near his post provided he does not have to leave his post to do so. If necessary, the guard will contact the commander of the relief for instructions.

(3) A guard apprehends all suspicious persons and all persons involved in a disorder occurring on or near his post provided he does not have to leave his post to do so. In apprehending persons, the guard will use only necessary force to overcome any resistance. Apprehension of persons should be included in special orders or guard instructions. All persons apprehended are turned over to the commander of the relief.

(4) All persons, regardless of rank, are required to respect members of the guard in the performance of their duties.

(5) A guard will remain on post and continue to perform all duties required on that post until he is relieved by proper authority.

(6) If a guard requires relief because of sickness or for any other reason, he will notify the commander of the relief and wait until he is replaced by another guard or has permission from the proper authorities to leave his post.

(7) If a guard is not relieved at the expiration of his tour of duty, he does not abandon his post. He will contact the commander of the relief for instructions.

(8) Guards leave their posts for meals as specifically directed by the commanding officer. Normally, this is accomplished by arranging for early and late meals for guards going on and coming off post.

(9) When ordered by proper authority, or prescribed in the special orders, a guard on the last relief of a post may be directed to leave the post at the proper time and return to the guardhouse where he reports to the commander of the relief on duty.

b. Number 2. I will obey my special orders and perform all my duties in a military manner.

(1) A guard will familiarize himself with the special orders for his post prior to being posted. The guard will obey, execute, and enforce all special orders pertaining to his post.

Note. The commander of the guard is responsible for insuring that all guards understand their special instructions prior to being posted.

(2) In addition to his special orders, a guard is responsible to obey and carry out any orders or instructions from the commanding officer, field officer of the day, and officers and noncommissioned officers of the guard. No other persons are authorized to give a guard orders or instructions. Any special instructions for a guard should be issued through the guard's chain of command.

(3) Guards on post will pass instructions to their relief when appropriate. The information is also given to the commander of the relief. Example: A guard on duty at an ammunition dump discovers a hole in the fence during his tour of duty. Upon finding the hole, the commander of the relief is notified. The guard will pass this information to his relief so that special attention can be paid to that portion of the fence until the hole is repaired.

(4) The guard will perform his duties in a military manner and serve as an example to others.

(5) The guard is courteous to all persons. He will talk to no one except in the line of duty. When persons make proper inquiries of a guard, he answers them in a courteous manner.

(6) A guard on an interior guard post maintains an erect and soldierly bearing. The weapon is carried in a manner prescribed by the commanding officer or commander of the guard. (A guard armed with a rifle, carbine, or shotgun may be allowed to shift his weapon to left shoulder arms to reduce fatigue.)

(7) Guards on post salute individuals as prescribed in AR 600-25.

(a) A sentry, on a post which does not require challenging, carrying a weapon at sling arms, will render the hand salute upon recognition of an officer.

(b) A sentry, on a post which *does not* require challenging, carrying a weapon at right (left) shoulder arms, will, upon recognition of an officer, halt and present arms as prescribed in the manual of arms FM 22-5. When the officer returns the salute the guard will return to right (left) shoulder arms and resume his duties.

(c) A sentry armed with a pistol, on a post which *does not* require challenging, will, upon recognition of an officer, render the hand salute.

(d) No salute is given by a guard who is engaged in a specific duty, the performance of which prevents saluting.

(8) A guard talking with an officer does not interrupt the conversation to salute another officer; however, if the officer salutes a senior, the guard also salutes.

(9) The special orders will specify the time for challenging.

(a) When challenging, a guard, armed with a rifle, carbine, or shotgun will challenge from the position of port arms as described in the manual of arms in FM 22-5. If armed with a pistol the guard will challenge from the position of raise pistol.

(b) After challenging, a guard will remain in the challenge position until the individual challenged is allowed to pass, depart, or is turned over the commander of the relief.

(c) Sentinels on posts requiring challenging will not render salutes.

Note. The sentinel's primary mission is to guard his post. Requiring salutes places the individual in a vulnerable position. The sentinel will, however, display all other military courtesy and respect while in conversation with an officer.

(d) Challenging one person or a group:

1. If a guard sees any person on or near his post during the time for challenging, he positions himself so that he can control the situation. If possible, he should be out of sight when challenging. When the person is approximately 30 steps, or at sufficient distance to allow the guard time to react, the guard will assume the correct challenge position and command "HALT!" When the person has halted, the guard asks, "WHO IS THERE?" The guard may advance toward the person while challenging to put himself in a better position. When the guard is in the best position to pass or apprehend the person, he requires the person to advance towards him, remain in position, or advance to a particular place, face toward the light, or to take any position necessary to determine whether the person should be passed, denied, or turned over to the commander of the relief.

2. The guard permits only one member of a group to approach him for identification.

3. If persons are in a vehicle, the guard proceeds as if they were on foot. If necessary to carry out his duties, he may have one or all of the passengers dismount.

4. After halting a group and receiving an

answer indicating that it is authorized to pros, the guard says, “Advance one to be recognized.” After he has recognized the one advanced, the guard says, “Advance, Sergeant Smith,” naming the person (or group) allowed to advance. If the answer is “Friends,” the guard says, “Advance one to be recognized.” After recognition he says, “Advance, friends.”

5. The guard satisfies himself beyond a reasonable doubt that those challenged are what they represent themselves to be and that they have a right to pass. If he is not satisfied, he detains the person and calls the commander of tile relief. Normally, the guard will accept a reasonable answer for identification if the post is not a vital area and the persons are not suspicious looking.

Note. A visual check of an individual’s ID card is considered the best means of identification when doubt exists.

(e) Challenging two or more persons or groups—

1. If two or more persons or groups approach the guard’s post from different directions at the same time, they are halted in turn and remain halted until advanced by the guard.

2. When two or more groups are halted at the same time, the senior is advanced first.

3. A guard advances different persons or groups with the following priority: commanding officer, field officer of the day, officer of the day, officers of the guard, officers, patrols, reliefs, noncommissioned officers of the guard in order of rank, and friends.

4. If a person or group has been advanced and is talking with the guard, the guard halts any other person or group that may approach, but advances no one until the person or group with whom he is talking leaves. He then advances the senior of the remaining group.

5. A guard must always be alert and never be surprised. He never permits two persons or groups to advance to his post at the same time.

6. Confusing or misleading answers to a guard's challenge are not acceptable. However, the answer "Friend" is not considered misleading and is the usual answer of an inspecting officer or patrol when they do not wish to reveal their official capacity.

(10) During his tour of duty a guard is required to execute orders of no one but the commanding officer, field officer of the day, officer of the day, and officers of the guard; however, any officer may investigate apparent violations of regulations by members of the guard. In the event of an inspecting officer, or any other person in the military service, finding an irresponsible guard on post (Art. 113, Uniform Code of Military Justice), it is his duty to notify the commander of the guard or a noncommissioned officer of the guard and stay on the post until a qualified guard is posted.

(11) A guard surrenders his weapon to, and only on order of, a person from whom he lawfully receives orders while on post. These persons should not order a guard to surrender his weapon for inspection or any other purpose unless an emergency exists.

c. Number 3. I will report violations of my special orders, emergencies, and anything not covered in my instructions, to the commander of the relief.

(1) A guard reports all violations of his special orders to the commander of the relief. He apprehends the offender, if necessary.

(2) A guard reports all emergencies that occur on or near his post. The guard will take whatever action is prescribed by his special orders or guard instructions. Anytime the guard is in doubt as to what action to take, or it is not covered in his special orders, he will call the commander of the relief for instructions or assistance.

(3) In case of fire, occurring on or near his post, the guard calls, "Fire, Post Number (Two)." He alerts the occupants, if it is an occupied building. He gives the alarm or insures one has been given. If possible, he extinguishes the fire. He helps direct the fire fighting apparatus to the fire. He notifies the guardhouse of his actions as soon as possible.

(4) A guard reports any disorder occurring on or near his post. He takes police action as prescribed in his special orders or guard instructions. If assistance is required, he calls, "The Guard, Post Number (Four)."

(5) If the danger is great, he fires his weapon into the air three times in rapid succession before calling. When instructed to do so, guards give warnings of air, CBR, and other attacks. Guards should receive special training if they are to act as chemical, biological, and radiological (CBR) sentinels while on post.

11. Special Orders

a. Special orders are established by the commanding officer and differ for various posts depending upon the nature of the area being guarded. They are based on the following considerations:

(1) *Realism*. Special orders are designed for a particular post, since two posts on an installation are seldom identical. The orders for each post are devised to provide increased protection for the sentinel concerned by locating him behind natural or artificial obstacles which make surprise difficult. This calls for flexible and imaginative planning when drawing up special orders. For example: Ammunition dump security at a critical installation would be more elaborate and tactically oriented than security of a post exchange.

(2) *Clarity*. Special orders should be stated in plain language that can be clearly understood by the guard on post. The commander of the relief clarifies any doubt as to their meaning before posting a guard.

b. The commanding officer is responsible for keeping the special orders up to date and publishes any changes immediately.

c. Copies of special orders are continuously and conspicuously posted in the guardhouse for reference. A copy of the special orders may be posted on a fixed post or the guard may be required to carry a copy of the special orders with him while on duty.

d. The special orders for each guard post should explain (or diagram) the post location, boundaries, and any particular orders for the post, including those conditions under which force will be used.

e. Additional special orders received by a guard before going on guard and while on post are passed on to the guard who relieves him. These additional orders may be written or oral.

12. Inspection of a Guard by an Officer

When a guard is asked by an inspecting officer, “What are your orders?” the proper answer is: “Sir, my orders are of two classes, general and special. My general orders are: Number One: I will guard everything within the limits of my post and quit my post only when properly relieved. Number Two: . . .” and he continues to recite his general orders until he is stopped by the officer or until he has recited all of his general orders. He should be able to answer any question(s) pertaining to the special orders for his post.

CHAPTER 5

MAIN GUARD

Section I. GENERAL

13. Composition

The main guard consists of patrols, fixed posts, and a reserve. Either patrols or fixed posts, or a combination of the two, may be used. In any case, the main guard maintains a reserve (para. 27).

14. Strength

The main guard consists of one officer of the day; one or more commanders of the guard; one or more sergeants of the guard; a relief commander for each relief; and the necessary number of guards. The number of guards needed for routine daytime duty is ordinarily much smaller than the number required at night or on Sundays and holidays. When it is necessary to have increased supervision and control of a relief, an assistant commander of the guard and an assistant sergeant of the guard may be detailed.

15. Arms and Equipment

a. Guards are armed and equipped according to their particular duty. Rifles, carbines, pistols, shotguns (FM 19-60), riot clubs (FM 19-5), or other weapons are used. Guards must be qualified to use

the weapon with which they are armed. If they are not armed with their individual weapon, they must be familiar with the weapon with which they are armed (shotguns, riot clubs).

b. Guards cover their posts on foot, in motor vehicles, or by other types of transportation; however, the exact method is prescribed by the commanding officer.

Section II. DUTIES OF PERSONNEL

16. Commanding Officer

a. The commanding officer details a guard sufficient to provide for the security of personnel, government property, and buildings within his jurisdiction. He requires a vigilant and thorough performance of guard duty. The commanding officer gives his orders, or has them given by his representative, to the officer of the day and prescribes regulations and special orders for the guard.

b. Daily, at a designated time and place, the commanding officer, or his representative, receives the reports of the officers of the day. He, or his representative, examines the guard report, relieves the old officer of the day, and gives the new officer of the day his instructions.

c. At those installations where confinement facilities are available, the commanding officer supervises the stockade and prisoners personally to insure compliance with the articles of the Uniform Code of Military Justice and AR 190-4. He specifies the duties of the correctional officer and the officer of the day with respect to prisoners.

d. The commanding officer's responsibility for safety regulations is given in appendix D.

17. Field Officer of the Day

a. A field grade officer is detailed as field officer of the day. During his tour of duty he is the commanding officer's personal representative.

b. His tour begins when he reports to the commanding officer or his representative for duty and terminates when he is relieved by the same authority. The usual tour of duty for the field officer of the day is 24 hours.

c. He is assigned various duties pertaining to the security of the command depending upon local directives. Normally, one of these duties is to supervise the interior guard and parallels closely the responsibilities of the officer of the day (para. 18). His primary concern, in his role as a supervisor, is to see that the guard performs its assigned tasks.

18. Officer of the Day

a. The officer of the day is responsible for the proper performance of duty by the main guard and, when so directed, for other guards. He is charged with executing all orders of the commanding officer relating to guard duty.

b. His tour begins when he receives the instructions of the commanding officer and ends when he is relieved by the same authority. The usual tour is 24 hours.

c. In the absence of special instructions from the commanding officer, the officer of the day inspects the guard and guards on post as often during the

day and night as he considers necessary; however he inspects them at least once between midnight and daylight.

d. Whenever he considers it necessary, he directs the commander of the guard and noncommissioned officers of the guard to inspect the guards on post.

e. In case of alarm, he acts immediately to protect life and government property and to preserve order. If necessary, he uses the guard to assist him.

f. In the performance of his duties, he takes orders only from the commanding officer or field officer of the day however, during an emergency, when there is great danger, the senior officer present may give orders to the officer of the day for the use of the guard.

g. At those installations where confinement facilities are available, the officer of the day verifies the count of prisoners and inspects the stockade at premises as directed by the commanding officer. He makes at least one inspection between midnight and daylight.

h. He signs the guard report, adding to it his own remarks, and submits it daily to the commanding officer.

i. The old and new officers of the day report to the commanding officer, or his representative, immediately after guard mount. Upon presenting themselves, the old officer of the day stands on the right of the new and both salute. The old officer of the day salutes again and reports, "Sir, Captain Jones reports as old officer of the day," and presents the guard report. As soon as he is relieved, the old officer of the day salutes and leaves. The new

officer of the day then salutes and reports, “Sir, Captain Smith reports as new officer of the day.” After receiving his instructions, the new officer of the day salutes and leaves.

j. The officer of the day is responsible for the property of the guard. He conducts a joint inventory of property with the old officer of the day to determine the presence and serviceability of the guard property.

k. The officer of the day keeps the guard informed of his location at all times.

l. His responsibility for safety regulations appears in appendix D.

19. Commander of the Guard

a. The commander of the guard is responsible for the instruction, discipline, and performance of the guard. He is also responsible for the security of ammunition and weapons of that part of the guard not on post.

b. He obeys the orders of the commanding officer, field officer of the day, and officer of the day. He reports to the officer of the day any additional orders given to the guard by himself or other authorized persons. He gives his successor all of the instructions and information about his duties.

c. The commander of the guard makes sure that all members of the guard are correctly instructed in their orders and duties and that they understand and properly perform them. He questions all members of the guard about the instructions they may have received, including the use of the countersign (chap 9).

d. He inspects the guard as directed by the office of the day, making certain that patrols and guard on fixed posts do their duties. He assures himself that the men, their arms, and their equipment are in proper condition. For inspections by other officers, the commander of the guard prepares the guard in each case as directed by the inspecting officer. He inspects each relief daily while it is on post and as often as prescribed by higher authority and makes at least one of these visits between midnight and daylight. He insures that the special orders for each post and member of the guard are posted in the guardhouse, and, if practicable, on each post.

e. When both old and new guards are at the guardhouse, the commander of the guard who is senior in rank is responsible for proper action in case of emergency.

f. When the commander of the guard leaves the guardhouse for any reason, he informs the next subordinate in command and the commander of the relief on post of his destination and probable time of return. Except in emergencies, the commander of the guard may divide night duty with the next in command; however, he retains his responsibility. The person on watch must be on the alert constantly.

g. When an alarm is raised, the commander of the guard forms the reserve as soon as practicable. If the situation is serious he notifies the officer of the day and commanding officer.

h. He makes certain that guard details for raising and lowering the flag at reveille and retreat, and for firing salute guns, are organized in time to

carry out these duties. He sees that the flags are kept in the best possible condition and that they are never handled except in the performance of duty. When flags are not in a serviceable condition, he reports that fact to the officer of the day.

i. He makes sure that all guards are relieved on time.

j. Unless otherwise ordered, he may permit members of the guard to leave the guardhouse when not on post. This does not include the reserve.

k. He holds at the guardhouse all persons apprehended or taken into custody by members of the guard. He reports the circumstances to the officer of the day who decides what action to take.

l. When any person is apprehended by members of the guard, the commander of the guard insures that the person has been searched for unauthorized articles and reports the facts to the officer of the day immediately.

m. He prepares the guard report and presents it daily to the officer of the day.

n. He prescribes the duties of the assistant commander of the guard when such an officer is detailed.

o. His responsibility for safe regulations appears in appendix D.

20. Sergeant of the Guard

a. The sergeant of the guard is the senior non-commissioned officer of the guard. He performs the duties and assumes the responsibilities of the commander of the guard, if there has been no officer so detailed.

b. He supervises the other enlisted members of

the guard, and is familiar with their orders and duties.

c. He insures that the property of the guard is properly cared for.

d. Each day he prepares duplicate lists of the names of the noncommissioned officers and sentinels of the guards, showing the reliefs and posts or duties of each. He keeps one list and gives the other to the commander of the guard.

e. He makes sure that all reliefs are turned out for posting at the proper time.

f. He checks to see that the relief commanders understand their duties thoroughly and carry them out promptly and efficiently.

g. He insures that other noncommissioned officers of the guard inspect the guard as prescribed.

h. When he is absent temporarily from the guard house, he directs the commander of the relief on duty to act as sergeant of the guard.

i. If the relief commander, whose relief is on post, is called away from the guardhouse, the sergeant of the guard replaces him temporarily or appoints another noncommissioned officer to carry out the duties of the absent relief commander (para 21).

j. He is responsible for the proper policing of the guardhouse and the grounds around the guardhouse.

k. He reports to the commander of the guard anything suspicious or unusual and notifies him of all persons apprehended by the guard.

l. He forms the guard whenever necessary.

m. His responsibility for safety regulations appears in appendix D.

21. Relief Commander

a. Relief commanders are the next senior noncommissioned officers of the guard.

b. They receive and obey orders only from the commanding officer, field officer of the day, officer of the day, commander of the guard, and the sergeant of the guard.

c. Each relief commander assigns the members of his relief to posts. These assignments are not changed except by the commander of the guard or higher authority.

d. Daily, each relief commander makes a duplicate list of the members of his relief, including himself. He gives one copy to the sergeant of the guard and keeps the other. This list shows the number of the relief, the post to which each member is assigned, and the member's name and organization.

e. The commander of the relief instructs his relief as to their orders and duties and makes certain that each guard understands them. He familiarizes himself with the special duties of every guard on his relief.

f. He reports immediately to the sergeant of the guard all violations of regulations and unusual occurrences.

g. At least one noncommissioned officer is kept constantly on the alert at the guardhouse, usually the relief commander whose relief is on post. This noncommissioned officer takes his post (as prescribed) in the guardhouse and does not fall in with the guard when it is formed. He keeps his weapon constantly with him. When necessary for him to leave his post, he notifies the sergeant of the guard, who takes his place or designates another noncom-

missioned officer to do so. He makes sure that no person enters the guardhouse without authority.

h. He goes at once to any guard who calls for the commander of the relief.

i. He is responsible for calling his own relief and forming it promptly when the guard is turned out.

j. He makes sure that tents or bunks for his relief are located close together so that he can find all the members of his relief and turn them out quickly and without confusion.

k. He awakens the commander whose relief is next on post in time to form and post the relief at the proper hour (para 50).

l. During the time for challenging, he challenges all suspicious persons he may observe. He advances them using the method described for guards on post para 10 *b* (3)).

m. He examines persons halted and detained by a guard. If he doubts their authority to be there, he takes them to the sergeant of the guard or the commander of the guard.

n. He apprehends all suspicious persons, disturbers of the peace, and persons caught, or suspected of, committing a crime. Persons apprehended by the commander of the relief or by guards are taken to the commander of the guard at once.

o. His responsibility for safety regulations appears in appendix D.

22. Guards

a. Privates and specialists are normally assigned posts. Noncommissioned officers may be assigned posts at the discretion of the commanding officer.

b. Guards are assigned to reliefs by the sergeant or the guard and to posts by the commander of their relief. Guards are not changed from one relief to another without authority.

c. They must memorize, understand, and comply with the general orders for guards. In addition, guards must understand and comply with special orders applying to their particular posts, including the use of the countersign and parole word (chap 9), if they are in effect.

d. When a guard is posted at the guardhouse he is Guard No. 1. While on post, he has direct access to the commander of the relief. His general orders are the same as those for other guards.

e. The observance of safety regulations by guards is explained in appendix D.

Color Guards

When the colors are unfurled and posted outdoors, guards may be furnished. They are detailed and governed by the same regulations as other members of the main guard.

Section III. PATROL SYSTEM

24. General

a. The patrol system is used in the main guard wherever practicable and is most suitable when large areas are guarded. Motor transportation is used whenever possible. The functioning of patrols is checked by timeclocks or periodic reporting by telephone, in person, or by other means, and by frequent inspections. If practicable, patrols are quartered together, generally at the guardhouse,

and a system of wire or radio communication is provided between patrols and the guardhouse.

b. Regulations for the duties, conduct, strength, and posting of the patrol elements of the guard are published by the commanding officer to suit local conditions.

25. Personnel

The commanding officer determines the size of patrols. Certain key men may obtain guard duty permanently while the others may be detailed semi-permanently. Generally, each patrol consists of two guards.

26. Reliefs

The daily tour for each patrol is ordinarily from 6 to 8 hours, and each relief is inspected before going on duty. The patrols move directly to their post, from the guardhouse. One patrol relieves another by meeting at a particular point at a prearranged time. The patrol relieved reports back to the guardhouse immediately.

27. Reserve

A reserve large enough to meet any local emergency is maintained at the guardhouse. The commanding officer prescribes the strength and conduct of the reserve.

Section IV. FIXED POST SYSTEM

28. General

The fixed post system may be used to complement the patrol system. Normally, the fixed post guard is

changed daily, and guards are relieved at their posts every 2 hours. Usually, posts are covered on foot in this system.

29. Personnel

The duties of all personnel in a fixed post system of interior guard duty are described in paragraphs 16 through 23.

30. Fixed Post Reserve

Normally, the reliefs not on post are the fixed post reserve. It is large enough to meet any local emergency and is maintained at the guardhouse. The commanding officer prescribes the strength and conduct of the reserve.

CHAPTER 6

GUARD MOUNTING

Section I. GENERAL

31. Requirements

Uniform, arms, and equipment for guard mounts are prescribed by the commanding officer. If armed, guards must have completed range firing (qualification or familiarization) or training (app D) with the weapon they use on guard duty.

32. Forming the Guard Detail

The first sergeants of the companies furnishing guard details form the guard detail in the company area. Each first sergeant verifies the detail to include verification that weapons qualification or familiarization requirements have been met, inspects it, replaces men who do not present a good appearance or have not qualified with their weapon, and order the senior member to march the detail to the assembly area.

Section II. GUARD MOUNT (INSPECTION ONLY)

33. General

Guard mount may consist of an inspection only. This inspection is normally conducted in the vicinity of the guardhouse. The officers and noncommis-

sioned officers of the guard are detailed for a specific duty by roster.

34. Assembly of the Guard

The senior member of the guard detail reports the detail to the sergeant of the guard when it arrives at the assembly area. The sergeant of the guard organizes the guard into three reliefs and appoints a relief commander for each relief. The commanders of the relief organize their reliefs into specific, numbered posts. Supernumeraries form to the left of the designated relief. Where feasible, the guard is organized in a manner that maintains unit integrity; e.g., if one unit furnished the guard, members of the relief are from the same subelement; if more than one unit furnished the guard, reliefs are organized by unit (1st relief, Co A; 2d relief, Co B)

35. Formation of the Guard

a. The sergeant of the guard forms the guard by commanding FALL IN. The commander of the first relief falls in so that when his relief is formed at normal interval to his left, it will be three steps in front of and centered on the sergeant of the guard. The second and third reliefs form behind the first relief, each man covering the corresponding numbered man in the first relief. Supernumeraries form to the left of the designated relief at normal interval. The sergeant of the guard commands INSPECTION, ARMS, READY, PORT, ARMS, ORDER, ARMS. He then faces about.

Note. If the commander of the guard is not to position the sergeant of the guard may face about and give the guards

AT, EASE. Upon seeing the commander of the guard moving into position the sergeant of the guard will command the guards to attention and face about. The sergeant of the guard will remain at sling arms throughout the entire guard mount.

b. The commander of the guard takes his post six steps in front of and centered on the guard. The sergeant of the guard renders the appropriate salute and reports, "Sir, all present," or "Sir, (so many) men absent." After the commander of the guard returns the salute, the sergeant of the guard faces to the right in marching, marches around the right flank of the platoon and halts one step to the rear, centered on the guard, and executes a right face (fig 2).

c. The officer of the day takes his post 18 steps in front of and centered on the guard. The commander of the guard faces about, salutes and reports, "Sir, all present" or, "Sir, (so many) men absent." The officer of the day returns the salute and directs PREPARE FOR INSPECTION.

36. Preparing the Guard for Inspection

a. On the directive PREPARE FOR INSPECTION the commander of the guard faces about without saluting, commands OPEN RANKS, MARCH. The guards open ranks march as outlined in FM 22-5. After the guards have opened ranks the commander of the guard commands DRESS RIGHT, DRESS, alines the formation, returns to his original position facing the guards and commands READY, FRONT. He then faces about, salutes, and says, "Sir, the guard is prepared for inspection." The officer of the day then inspects the guards.

During the inspection the officer of the day order guards who are not satisfactory for guard to fall out to the rear of the formation and await further instructions from the sergeant of the guard. When a man is relieved the officer of the day commands **SUPERNUMERARY**. The supernumerary will move from his position to the post vacated. He takes his post by taking one step backward, faces to the right, and moves in the rear of the relief so that he will approach the vacated position from the rear. He halts, executes a left face, moves into position, halts and immediately comes to inspection arms. The officer of the day inspects the supernumerary then proceeds with the inspection. After inspecting the guard the officer of the day and the commander of the guard return to their original positions. The officer of the day halts 18 steps front of and centered on the guard. The command of the guard stops six steps in front of and centered on the guard and executes a right face.

b. If an orderly is to be selected, the officer of the day will announce his selection. He then commands **TAKE CHARGE OF THE GUARD**. Salutes are exchanged and the officer of the day departs.

Note. During the inspection the officer of the day may direct that the reliefs not being inspected be given at ease. In this case, the commander of the guard, upon completion of the inspection, will call the guards to attention while moving around the right flank of the formation.

The commander of the guard faces about and commands **CLOSE RANKS, MARCH**. The guard closes ranks the same as in platoon drill (FM 22-5). The commander of the guard commands **FALL OUT**. The guards move into the guardhouse. The com-

mander of the first relief prepares his relief to be posted. The orderly, if one was selected, reports to the commander of the guard for instructions.

c. If no officer is detailed as officer of the day, the commander of the guard assumes the duties of the officer of the day. If no officer of the day or commander of the guard is detailed, the sergeant of the guard prepares the guard for inspection and inspects it.

Note. The sergeant of the guard will assume the position of the commander of the guard.

Section III. INFORMAL GUARD MOUNTING

37. General

Informal guard mounting is held on the parade ground of the organization from which the guard is detailed. When the guard is detailed from more than one organization, it is held wherever the commanding officer directs. When a noncommissioned officer commands the guard at guard mount, he takes the post of and performs the duties prescribed for an officer.

38. Assembly of the Guard

The guard is assembled as prescribed in paragraph 34.

39. Formation of the Guard

a. The guard is formed as prescribed in paragraph 35.

b. If an officer has been detailed as commander of the guard, the sergeant of the guard faces about, renders the appropriate salute and reports, "Sir, all

present,” or, “Sir, (so many) men absent.” After the commander of the guard returns the salute the sergeant of the guard faces to the right in marching, marches around the right flank of the platoon, and halts one step to the rear, centered on the guard, and executes a right face.

Note. The sergeant of the guard will keep his weapon at sling arms throughout the entire guard mount.

c. If an officer has not been detailed as commander of the guard, the sergeant of the guard takes three steps forward and assumes the position of the commander of the guard (fig 2).

40. Reporting to the Officer of the Day

When the officer of the day arrives, the commander of the guard salutes and reports, “Sir, all present,” or, “Sir, (so many) men absent.”

41. Marching to Center

The officer of the day commands OFFICER AND NON-COMMISSIONED OFFICERS CENTER, **MARCH**. At the command of **MARCH**, the commander of the guard marches forward and halts three steps in front of the officer of the day (fig 3). On the command of **MARCH**, the commanders of the reliefs march forward and execute column left without command when on a line three steps to the rear of the commander of the guard. The third relief commander commands NONCOMMISSIONED OFFICERS, **HALT**, when they are centered on the commander of the guard. On the command of **MARCH**, the sergeant of the guard will move from his position around the right flank of the formation by the most direct route

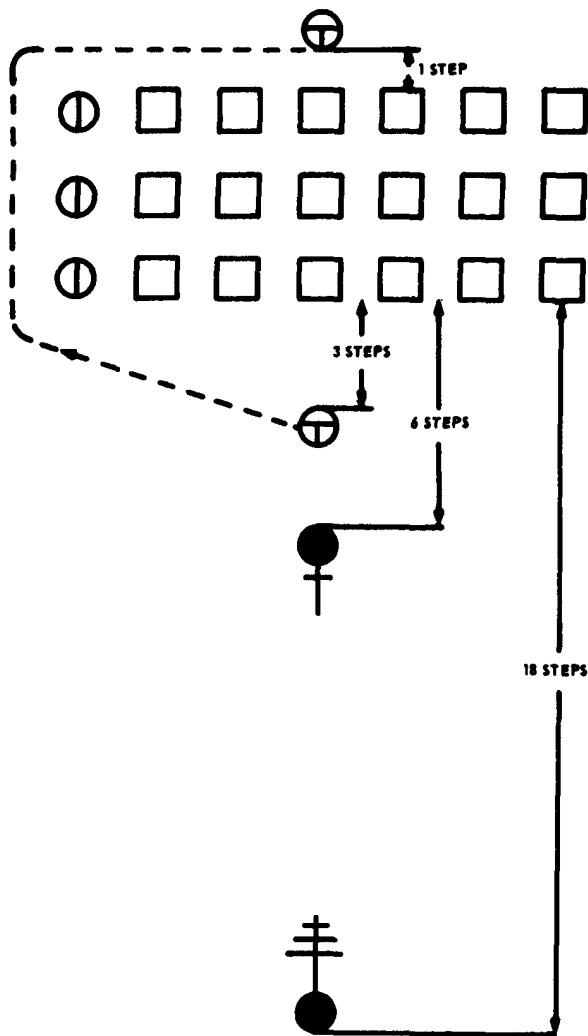

Figure 2. Formation for informal guard mount.

a position three steps behind the second relief commander (fig 3). Upon seeing the sergeant of the guard in position, the third relief commander commands **RIGHT, FACE** (fig 3).

Note. The commanders of the reliefs move at the order arms position. After the commander of the guard and the noncommissioned officers are in position the officer of the day marches forward, halts at normal distance in front of the commander of the guard, and designates "Commander of the Guard." He then faces to the half left and moves by the most direct route into position in front of the right flank commander of the relief and designates "Commander, Third Relief." He then faces to the right in marching, takes two steps, halts, executes a left face and designates "Commander, Second Relief." He then faces to the right in marching, takes two steps, halts, executes a left face and designates "Commander, First Relief." He then faces to the right in marching and moves by the most direct route behind the commanders of the relief, halts in front of the sergeant of the guard, executes a right face and designates "Sergeant of the Guard." He then faces to the left in marching and moves by the most direct route around the right flank of the commanders of the reliefs to his original position, halts, executes a left face (fig 4).

42. Return to Posts

The officer of the day commands **POST**. On this command, the commander of the guard and the sergeant of the guard face about and immediately step off, returning by the most direct route to their original positions. The commander of the guard is six steps in front and centered, facing the guards. The sergeant of the guard one step behind, centered on the guards. At the same time the commanders of the relief execute a right face and immediately step off returning to their original positions by the same route used to come center. They will execute the

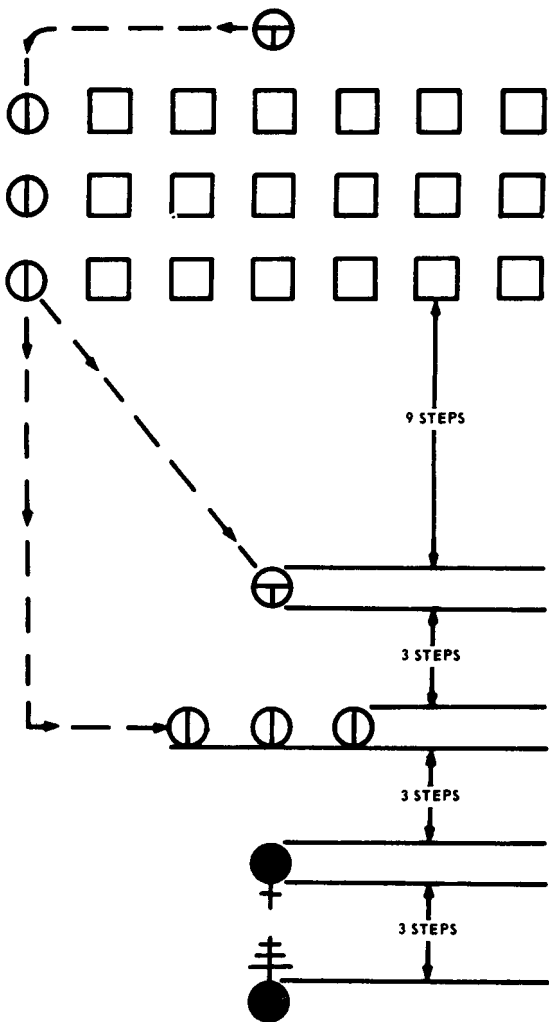

Figure 3. *Marching to center.*

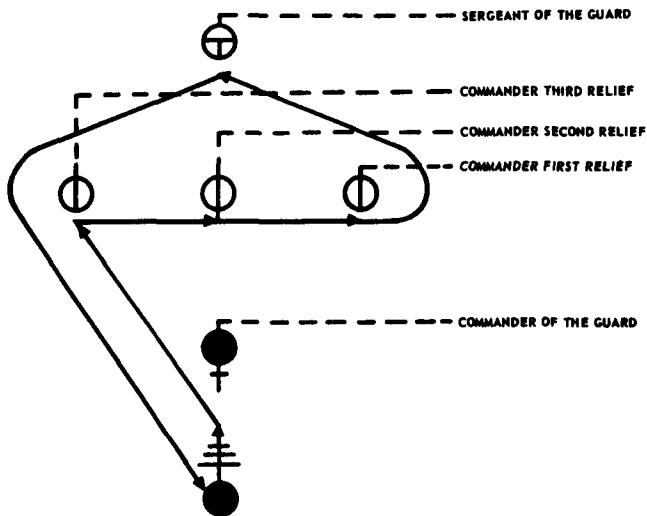

Figure 4. Designation of personnel.

column movement without command and halt when they arrive at their positions without command. Upon arriving at his original position and seeing the sergeant of the guard back in position, the first relief commander will command, ABOUT, FACE. The relief commanders will execute about face. At the same time the sergeant of the guard will execute right face (fig 5). Upon seeing all NCO back in position the commander of the guard will execute about face.

43. Inspecting the Guard

a. The officer of the day directs PREPARE FOR INSPECTION. The commander of the guard, without saluting, faces about and commands OPEN RANKS

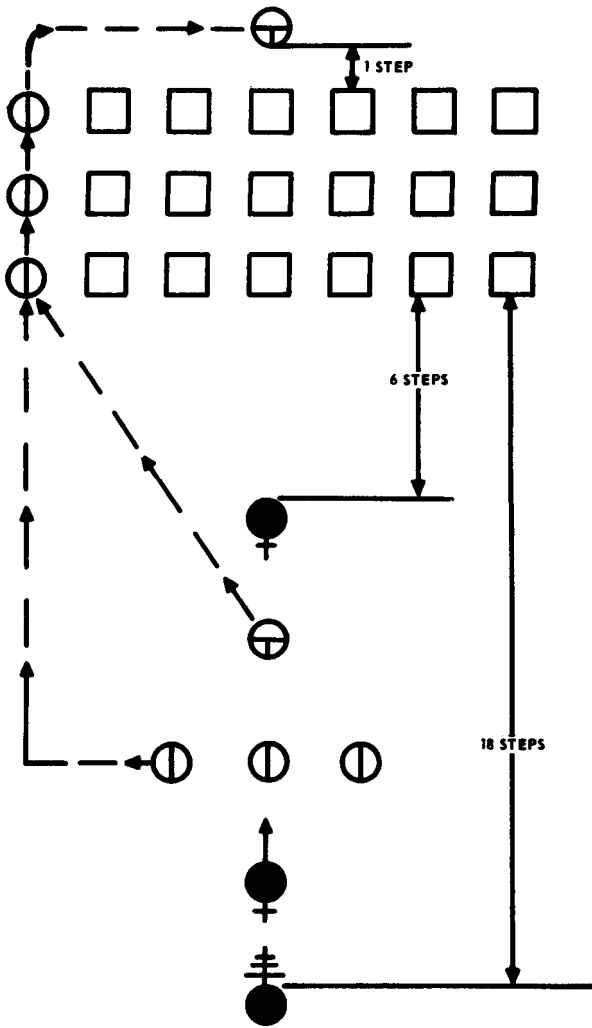

Figure 5. Return to posts.

MARCH. Ranks are opened and alined as describe in platoon drill, FM 22-5.

Note. The commander of the guard precedes the officer of the day on the inspection.

b. The officer of the day orders guards who are not presentable for guard to fall out to the rear of the formation and await further instructions. Supernumeraries (if any) replace the men who have fallen out. (The officer of the day reports discrepancies in personnel to the commanding officer, or his representative, when reporting for duty.)

c. After inspecting the guard, the officer of the day and the commander of the guard resume their original positions. The officer of the day commands **MARCH THE GUARD TO THE GUARDHOUSE.** Salutes are exchanged. The commander of the guard faces about and commands **CLOSE RANK MARCH.** He commands **RIGHT, FACE,** then positions himself one step in front of the second relief commander. On the command of right face, the sergeant of the guard faces to the left in marching and moves by the most direct route to his position one step to the rear of the last man in the second relief.

Section IV. RELIEVING THE OLD GUARD

44. Arrival of the New Guard at the Guardhouse

Before the new guard arrives at the guardhouse, the old guard forms in a line formation with two or more reliefs. The commander of the old guard positions himself six steps in front of and centered on the guard. The new guard marches past (12 step

in front of) the old guard. When the new guard is six steps from the left flank of the old guard, the commander of the new guard commands EYES, RIGHT. The commander of the old guard faces about and commands PRESENT, ARMS. He faces back to the front and renders the proper salute. When the new guard has cleared the right flank of the old guard, the commander of the new guard commands READY, FRONT. The commander of the old guard faces about, commands ORDER, ARMS, and faces back to the front.

45. Formation of the Old and New Guards at the Guardhouse

a. After the new guard executes ready front, the commander of the new guard commands, RIGHT FLANK, MARCH. At the command MARCH, he steps out of the formation and positions himself six steps in the rear of and centered on his guard. He halts the new guard when it is on line with and six steps to the right of the old guard. Then he commands ORDER, ARMS; ABOUT, FACE; LEFT FLANK MAN FIRST RELIEF VERIFY SIX STEP INTERVALS ; DRESS LEFT, DRESS (fig 6).

b. At the command DRESS, each man turns his head and eyes to the left (except the left flank men who look to the front) raises his left arm laterally, shoulder high, fingers extended and joined, and touches the man's shoulder to his immediate left. The left flank man of the first relief is the base for this movement. The first relief obtains the exact interval. Other reliefs obtain approximate interval and cover the same numbered man to their front.

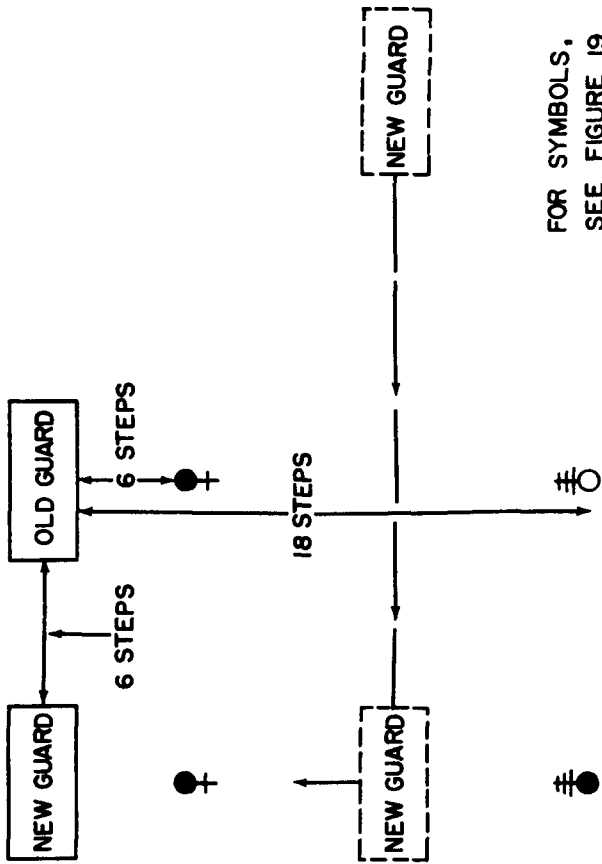

FOR SYMBOLS,
SEE FIGURE 19

Figure 6. Formations of the guard at the guardhouse.

c. At the command **DRESS**, the commander of the old guard marches by the most direct route to the right flank of the guard, halts facing the rear on line and one step to the right of the first relief commander. He faces to the right and alines the guard as described in platoon drill (FM 22-5).

d. After alining the last relief, the commander of the guard faces to the right in marching and moves to his original position, six steps in front of, centered on, and facing the guards. He commands **READY, FRONT**. At the command **FRONT**, each man lowers his arm to his side and turns his head and eyes back to the front. The commander of the guard then faces about.

46. Presenting New and Old Guards

After the new guard is in position, the commanders of both guards face about and command **PRESENT, ARMS**. Then they face each other and exchange salutes, face toward their respective guards, command **ORDER, ARMS**, and face back to the front.

47. Presenting the Guards to the Officer of the Day

a. After the new guard has been presented to the old guard, the new and old officers of the day take their posts 18 steps in front of and centered on their respective guards. Commanders of both guards face about, command **PRESENT, ARMS**, face back to the front, and salute their respective officer of the day.

b. After salutes have been exchanged, both commanders face about, command **ORDER, ARMS**, and face back to the front. When both have faced back to the front, the officers of the day face each other.

The new officer of the day salutes the old officer of the day. After salutes have been exchanged, both officers of the day face their respective guards.

48. Disposition of the New and Old Guards

a. After both officers of the day have faced their guards, the new officer of the day commands **POST THE FIRST RELIEF**. The new commander salutes the new officer of the day, faces about and commands **FALL OUT**. The guard reports to the guardhouse and the commander of the first relief reports to the command of the guard for instructions on posting his relief.

b. The old officer of the day commands **DISMISS THE GUARD**. The old commander salutes the old officer of the day, faces about, and commands **REST**. He then contacts the new commander and conveys any instructions and orders.

(1) If the old guard was furnished from one company, the commander of the old guard directs a noncommissioned officer of the guard to march the guard to the company area and dismiss it. The noncommissioned officer dismisses the guard by commanding **INSPECTION, ARMS; READY, PORT, ARMS; DISMISSED**.

(2) If the guard was furnished from more than one company, the old commander instructs the senior member of each company to march the guard detail to the company area and dismiss it. The guard is dismissed as described in (1) above.

(3) After the third relief of the old guard has been relieved, the commander of the relief reports to the commander of the new guard. The com-

mander of the new guard inspects the relief and orders the relief commander to march the relief to the company area and dismiss it. Salutes are exchanged. The relief is dismissed in accordance with (1) above.

Section V. POSTING RELIEFS

49. General

a. Before a relief goes to post, the commander of the relief assembles the guards and checks their appearances, fitness for duty, and the condition of their arms, if carried. He issues ammunition, supervises loading the weapons if required, and makes sure that the guards understand their instructions. When the relief is large, it may be more convenient to form the relief, call the roll, and inspect the guards in ranks.

b. The relief commander writes down the names of the guards, the numbers of their posts, the time he directed them to their post, and the time they report back to the guardhouse after being relieved. The commander of the guard keeps this record on file.

50. Posting Guards

a. The commander of the relief forms it by commanding FALL IN. The relief forms in two ranks, three steps in front of and centered on the relief commander. Guards assigned to even numbered posts (2, 4, 6, 8) form in the front rank. Guards assigned to odd numbered posts (1, 3, 5, 7) form in the rear rank. The commander of the old relief

⊙ ← COMMANDER OLD RELIEF

1 3 5 7

2 4 6 8

3 STEPS

⊙ ← COMMANDER NEW RELIEF

FOR SYMBOLS, SEE FIGURE 19

Figure 7. Forming the relief.

falls in at normal distance behind the guard for post No. 1 (fig 7).

(1) The commander of the new relief commands *INSPECTION, ARMS* (if arms are to be loaded, he gives the necessary commands at this time and makes certain that safety procedures are carefully observed); *READY, PORT, ARMS; ORDER, ARMS*.

(2) He commands *CALL, OFF*. The guards call off the number of their assigned posts, rear to front and from right to left.

(3) He salutes and reports to the commander of the guard, "Sir, the (first) relief is present and

ready to be posted,” or, “Sir (so many) men absent.” If the commander of the guard is a noncommissioned officer, the commander of the new relief salutes and reports, “Sergeant, the (first) relief is present and ready to be posted” or, “Sergeant, (so many) men absent.”

(4) After the commander of the guard (sergeant, of the guard) commands POST YOUR RELIEF, salutes are again exchanged. The commander of the new relief commands RIGHT, FACE; RIGHT SHOULDER, ARMS (if appropriate); and FORWARD, MARCH. He marches to the left of the last man, left file, at normal interval while the commander

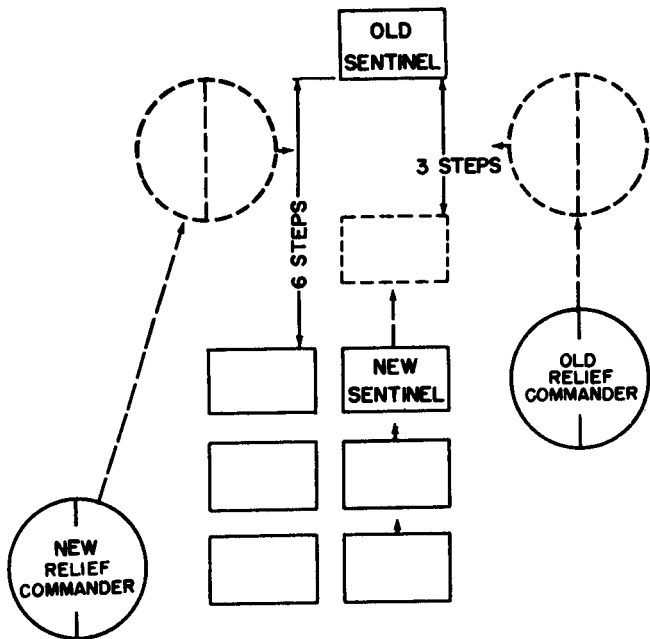

Figure 8. Posting and relieving guards.

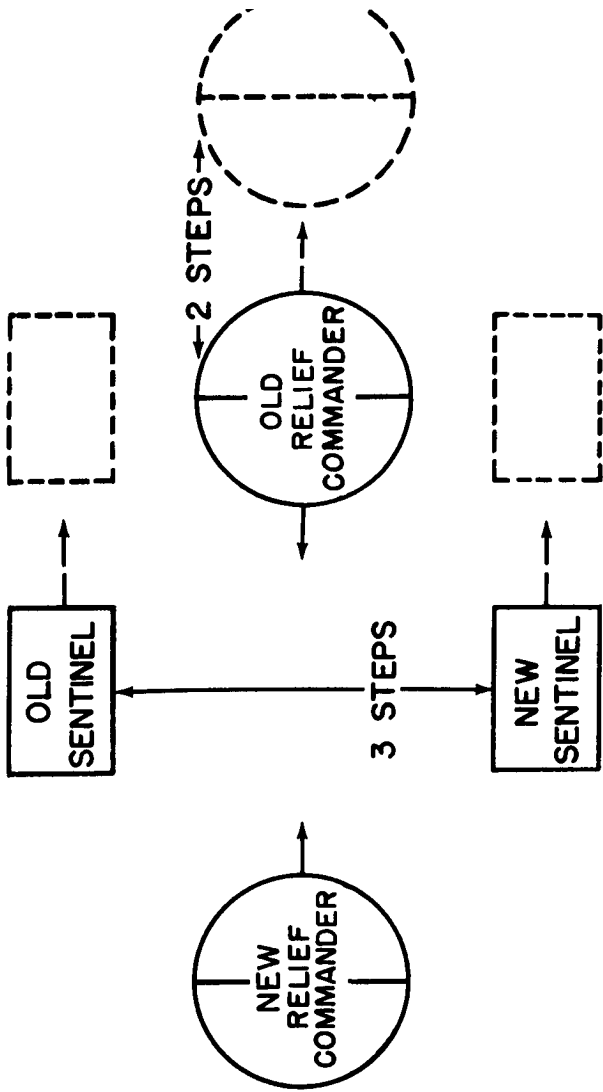

Figure Continued.

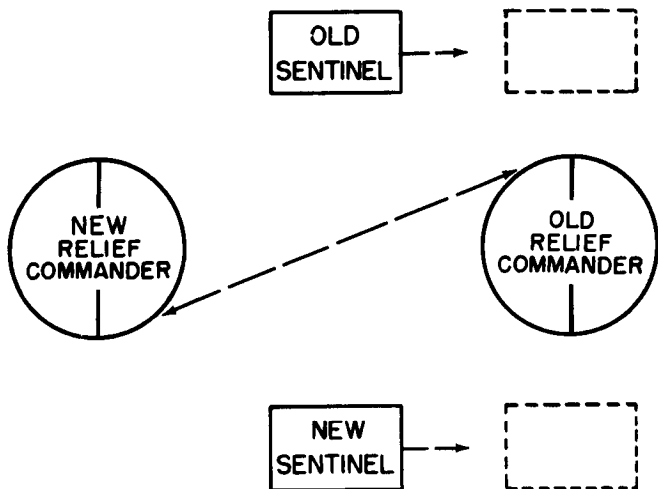

Figure 8—Continued.

of the old relief marches on the right of the first man, right file, at normal interval (1, fig 8).

b. During daylight hours, the commander of the new relief halts his relief six steps from the old guard and commands NUMBER ONE (TWO, or THREE). The *new* guard (called) marches forward and halts three steps in front of the old guard. If armed with the rifle, carbine, or shotgun he executes port arms. Both relief commanders advance and half so that they are three steps apart and centered between the two guards. Then they execute a left (right) face and face each other (2, fig 8). When the guard (called) marches forward, the other guards behind him in the formation move forward to fill his position.

(1) The commander of the new relief commands **TANSMIT YOUR ORDERS**, and the old guard transmits any changes in orders occurring during his tour or states, "Post and orders remain the same." The new relief commander then asks the new guard, "Do you understand your orders?" If the new guard understands his orders he replies, "Yes, I do." If not, he new relief commander clarifies the order or has the old guard explain.

(2) The commander of the new relief commands **GUARDS, POST**. At the command **POST**, both guards resume right shoulder arms, or sling arms if appropriate, face the new command, and march backward until they are on line with the commander of the old relief.

c. The commander of the new relief commands to his relief **FORWARD, MARCH**. The commander of the old relief takes two steps backward to clear the old guards (2, fig 8). The relief marches between the relief commanders and the relief commanders take their original positions as it passes them.

(1) The old guard takes his place at the rear of the relief as it passes him.

(2) The new guard stands fast until the relief has passed six steps beyond him and then he walks his post, or takes his prescribed position.

d. The commander of the old relief takes command when his last squad has been relieved.

(1) The commander of the new relief has the guard transmit his orders then commands **RELIEF COMMANDERS, POST**. Both commanders exchange positions by passing each other right shoulder to

right shoulder, halting, and facing about. Both guards stand fast (3, fig 8).

(2) After the relief commanders face about, the commander of the old relief commands **GUARDS, POST**. At the command **POST**, both guards resume right shoulder arms, or sling arms if appropriate, face the commander of the old relief, and march backward until they are on line with the commander of the new relief.

(a) The commander of the old relief commands (to his relief), **FORWARD, MARCH**.

(b) The commander of the new relief takes two steps backward to clear the old guard. The relief advances, the relief commanders take their new positions, and the old guard takes his place at the rear of the relief as it passes him.

e. When the old relief returns to the guardhouse, the commander of the old relief commands **RELIEF, HALT**, and the commander of the new relief falls out and takes his post in the guardhouse.

(1) The commander of the old relief commands **INSPECTION, ARMS** (if weapons are loaded, they are unloaded at this time and safety procedures are carefully observed); **READY, PORT, ARMS; DISMISSED**. He reports to the commander of the guard that his relief has been relieved and is present in the guardhouse.

(2) If the old relief was the third relief of the old guard, the relief commander dismisses his relief in accordance with paragraph 48 *b* (3).

f. During the hours of challenging, the commander of the new relief halts the relief when the guard challenges, “**HALT!**” “**WHO IS THERE?**”

The commander answers, "Relief." The guard commands, "ADVANCE OLD RELIEF COMMANDER TO BE RECOGNIZED." The old relief commander advances until the guard commands HALT! After he recognizes the relief commander, he commands ADVANCE RELIEF. The new relief commander marches the relief forward and halts it six steps from the old guard. The procedure for relieving the old guard is the same as in *b* above, except that when a new guard is armed with a pistol he comes to raise pistol after halting and when posted returns his pistol.

g. If transportation is utilized to post the relief, the guards are posted and relieved using the procedure described in *b* or *f*, above. The old and new relief commanders and the guard to be posted are the only members of the relief who dismount.

51. Posting Other Reliefs

a. To post a relief when there is no guard on the post, the commander forms his relief as prescribed in paragraphs 50 *a* (1), (2), and (3).

(1) He halts the relief six steps from the limits of the post concerned and commands NUMBER ONE (TWO OR THREE). The guard called takes three steps forward, halts, executes port arms if armed with the rifle or carbine, and faces to the left. The commander advances three steps in front of the relief, halts, and faces to the right, facing the guard. The guard, if armed with a pistol, executes raise pistol after facing to the left.

(2) The relief commander asks, "Do you understand your orders?" If he understands the order

the guard replies, "Yes, I do." If not, the commander explains as necessary.

(3) The relief commander commands POST. The guard executes right shoulder, sling arms, or return pistol, as appropriate, marches backward far enough to clear the relief, and walks his post when the relief is six steps beyond him.

(4) The commander commands to the relief FORWARD, MARCH, and resumes his original position as the relief passes him.

b. The officer of the day can authorize the reliefs to be divided into small groups, placing each group under a noncommissioned officer for posting, have guards posted individually, or, use a combination of these two methods.

(1) If guards are posted individually, the relief commander orders, "Guard, take your post."

(2) If guards are posted as a group, the relief commander orders, "Take your posts." Each guard then proceeds directly to his post. Guards relieve each other at a specified point and transmit changes in orders.

(3) A guard relieved individually proceeds directly to the guardhouse and reports to the commander of the old relief. The last guard on a post from which he will not be relieved by another guard proceeds directly to the guardhouse at a designated time.

c. The relief may be posted by only the new relief commander. The procedure is as described above except the old relief commander is not present. The new relief commander marches the old relief back

to the guardhouse and dismisses them (para 48 (3)).

Section VI. FORMAL GUARD MOUNTING

52. General

a. Uniforms, arms, and equipment for formal guard mounts are prescribed by the commanding officer.

b. Formal guard mounting requires a band and is held on the parade ground of the organization from which the guard is detailed.

53. Assembly of Band

The band takes its place on the parade ground at a point where its left flank is 12 steps to the right flank of where the guard will be (fig 9). The adjutant makes certain the guard is ready to be marched onto the parade ground (the guard has been faced to the right) and then signals the band to sound *Adjutant's Call*.

54. Assembly and Forming the Guard

a. The guard details are formed as prescribed in paragraph 32. When the band sounds assembly, each guard detail is marched to the point of assembly, off the parade ground, and reported to the sergeant of the guard.

b. The guard details are assembled and formed into a platoon as prescribed in paragraph 35. If there are more than 14 men per rank, the guard is divided into two platoons.

c. The assistant sergeant of the guard takes his post three steps in front of and centered on the

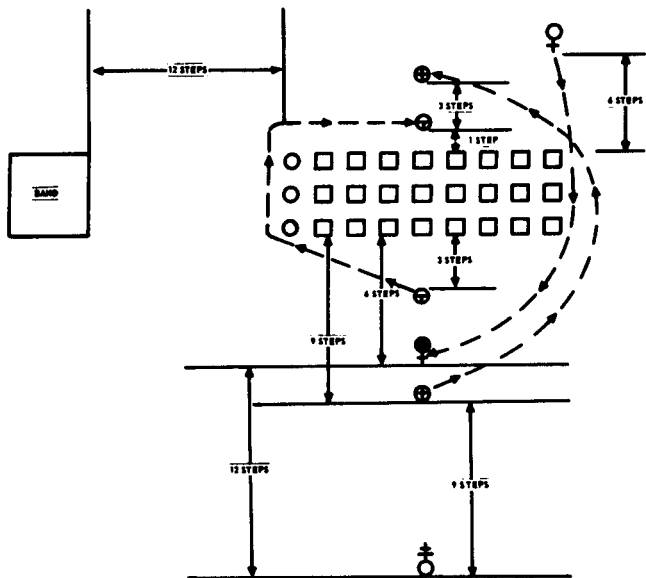

Figure 9. Formation of one platoon and posts of key personnel.

second platoon. Any remaining noncommissioned officers form on the left flank to equalize the number of men in each rank. After the platoons are formed, the sergeant of the guard faces the guard to the right and awaits the band to sound *Adjutant's Call* (figs 9 and 10).

55. Marching the Guard to the Parade Ground

a. Immediately following *Adjutant's Call*, the band plays march music. The adjutant, with the sergeant major on his left, marches forward on the first note of march music. The adjutant halts at his

post 18 steps in front of and facing the center of where the guard will be. The sergeant major continues forward and halts so as to take his post nine steps in front of and facing the center of where the guard will be.

b. The sergeant of the guard takes his post three steps to the left of the left file and centered on the guard. If two platoons are present he centers himself on the first platoon with the assistant sergeant of the guard centered on the second platoon. Immediately following *Adjutant's Call*, he marches the guard in column onto the parade ground. He approaches the parade ground from a direction near the final line on which the guard will form. He halts the guard when the head of the column is 12 steps from the left flank of the band and centered on the sergeant major. If there are two platoons the assistant sergeant of the guard will halt the second platoon three steps to the rear of the first platoon. At this time, the band stops playing. The sergeant of the guard (assistant sergeant of the guard) faces to the right and commands (ORDER, ARMS, if appropriate), LEFT, FACE (figs 9 and 10).

56. To Aline the Guard

The sergeant of the guard and the assistant sergeant of the guard, if there are two platoons, aline the guard as prescribed in FM 22-5.

57. Sergeant of the Guard Report

a. The sergeant of the guard (assistant sergeant of the guard) moves to his position three steps in front, centered, and facing the guard and command

READY, FRONT. On the command FRONT, the commander of the guard takes a position six steps behind the left flankman of the third relief. If there are two platoons the assistant commander of the guard takes his post behind the second platoon in the same position as prescribed for the commander of the guard. The sergeant of the guard faces about and renders the report, "All present" or "(so many) men absent," to the sergeant major. Salutes are exchanged and the sergeant major commands POST. The sergeant of the guard faces to the right in marching and moves by the most direct route around the right flank to his position one step to the rear and centered on the guard (fig 9).

b. If there is an assistant sergeant of the guard present, he executes the movements as in *a* above. At the command POST, he moves to his position behind the second platoon (fig 10).

58. Sergeant Major's Report

a. After the command POST, when the sergeant of the guard (assistant sergeant of the guard) is in position, the sergeant major faces about and reports to the adjutant, "Sir, all present," or "Sir (so many) men absent." Salutes are exchanged. The sergeant major faces about, marches to his post, three steps to the rear of and centered on the sergeant of the guard, halts and faces to the left. If there are two platoons, he positions himself three steps to the rear and centered on the guard (fig 10).

b. After the sergeant major has completed his report and faced about, the commander of the guard marches from his position in the rear of the guard,

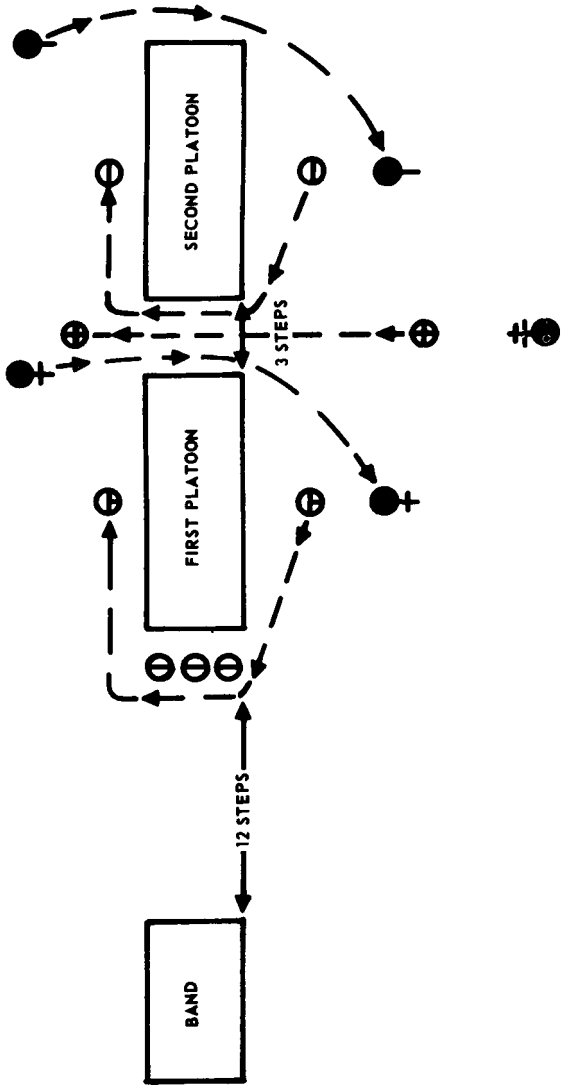

Figure 10. Formation of two platoons.

around the right flank, to his post six steps in front of and centered on the guard. If there are two platoons, the assistant commander of the guard, if present, takes his post in front of the second platoon (fig 10).

59. Marching to the Center

a. The adjutant commands OFFICER (or Officers) AND NONCOMMISSIONED OFFICERS CENTER, MARCH. The procedure for marching to the center is the same as in paragraph 41, except when there are two commanders of guard, the senior is designated “commander of the guard” and the junior “assistant commander of the guard.”

b. If there are two sergeants of the guard, the senior is designated “sergeant of the guard” and the junior, “assistant sergeant of the guard.” The post of the assistant sergeant of the guard is to the left of the sergeant of the guard at normal interval.

c. When two platoons are present, the commanders march to the center and form as shown in figure 11.

60. Returning to Posts

a. After designating the duties, the adjutant returns to his post and commands POST. When one platoon is present, posts are taken as described in paragraph 42 (fig 11).

b. When two platoons are present the assistant commander of the guard and assistant sergeant of the guard execute about face and move by the most direct route to their respective positions.

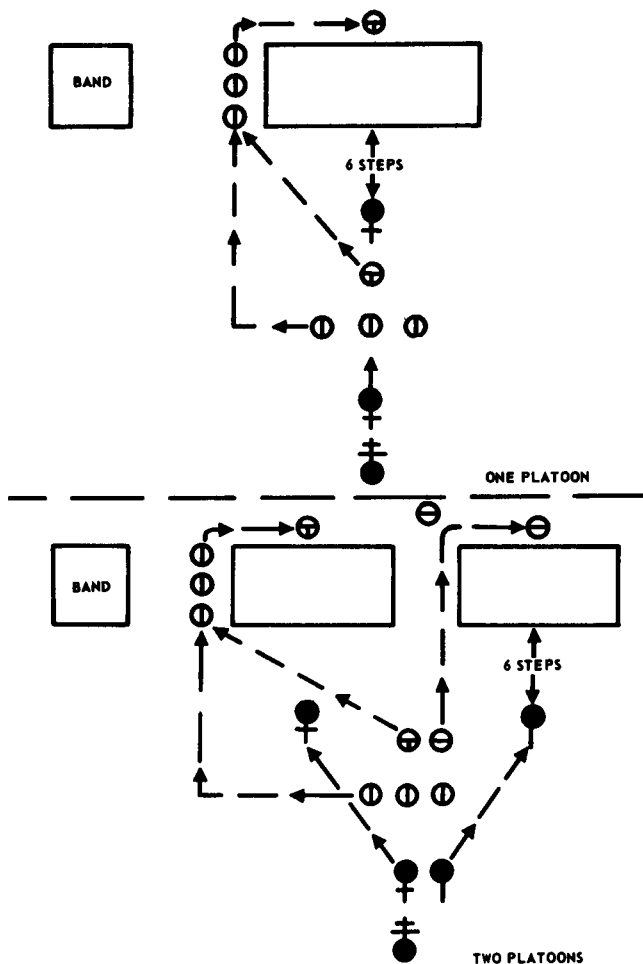

Figure 11. Officers and noncommissioned officers taking their posts.

1. Inspection of the Guard

a. During formal guard mount the adjutant, instead of the officer of the day, inspects the guard.

b. After the officer (or officers) and noncommissioned officers have taken their posts, the adjutant commands PREPARE FOR INSPECTION. The guard is prepared for inspection as described in FM 22-5.

c. During the inspection, he selects the orderly and color guards and orders men who are not prepared for guard to fall out and return to their organization. Substitutes for men who have fallen out report to the commander of the guard at the guardhouse.

d. The band plays during the inspection.

62. Closing Ranks

a. After the inspection, the commander of the guard orders the guard to close ranks and then he returns to his original post. If there is an assistant commander of the guard, he orders the second platoon to close ranks after it has been inspected. He then returns to his post in front of the second platoon (FM 22-5).

b. The adjutant takes his post 35 steps in front of, centered on, and facing the guard.

c. The new officer of the day posts himself 36 steps to the rear of the adjutant.

d. The old officer of the day posts himself three steps to the right of the new officer of the day.

63. Sound Off

a. The adjutant commands GUARD, ATTENTION; PARADE, REST; SOUND OFF, and then executes

parade rest. (The commander of the guard and the assistant commander of the guard do not give supplementary commands.)

b. At the command **SOUND OFF**, the band sounds off then moves forward playing. It passes to the left of the line between the commanders of the guard and the adjutant and then back to its position on the right where it halts and sounds off again (fig 12).

c. While the band troops the line, the officers of the day stand at attention.

64. The Adjutant's Report

The adjutant commands **PRESENT, ARMS**, faces about toward the new officer of the day, salutes and reports, "Sir, the guard is formed."

65. Marching in Review

a. The new officer of the day returns the salute and directs the adjutant, **MARCH THE GUARD IN REVIEW, SIR**. The adjutant faces about and commands **ORDER, ARMS; RIGHT, FACE**. At the command **FACE**, the guard and the band face to the right. The band marches to a position where its rear rank is approximately 24 steps in front of the leading platoon, halts, and faces to the left (FM 22-5). The commander of the guard assumes the position of platoon leader of a platoon in column. If present, the assistant commander of the guard assumes the same position in front of the second platoon. The adjutant takes a post three steps in front of the leader of the first platoon (commander of the guard). The sergeant of the guard takes a

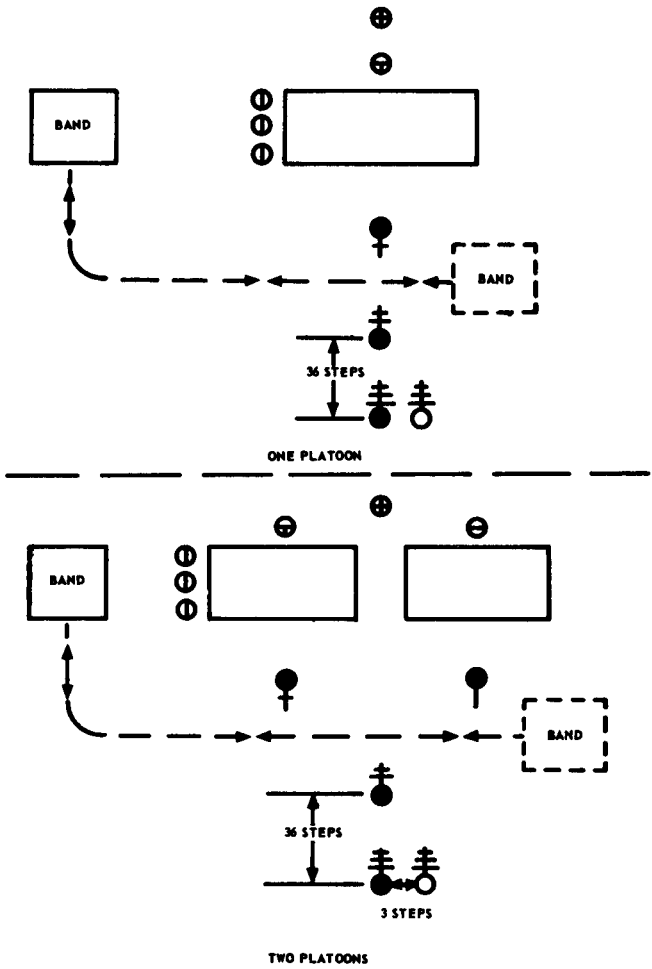

Figure 12. Sound off.

position one step behind, centered on the guard. If two platoons are present he assumes his position behind the first platoon. The assistant sergeant of the guard takes his position behind the second platoon. The sergeant major maintains his post until the last man of the last platoon clears his position and then falls in three paces behind and centered on the last platoon.

b. The adjutant commands **FORWARD, MARCH**, after giving the necessary manual of arms command.

c. The band begins playing on the command **MARCH**. The band and the guard march past the officer of the day (fig 13). The commander of the guard (first platoon leader) maintains a 24-step distance behind the band during the march in review.

d. When the adjutant is six steps from the office of the day, he commands, **EYES, RIGHT**.

(1) When there is one platoon, the officer of the guard, the adjutant, and the sergeant major execute the hand salute on the command **EYES, RIGHT**. When the sergeant major is six steps beyond the officer of the day, the adjutant commands, **READY, FRONT** (fig 13).

(2) When there are two platoons (fig 14), the adjutant commands **EYES, RIGHT**, for the first platoon. He commands **READY, FRONT**, for the first platoon when the last rank is six steps beyond the officer of the day. The assistant commander of the guard commands **EYES, RIGHT**, for the second platoon when he is six steps from the officer of the day, and **READY, FRONT**, when the sergeant major is six steps beyond the officer of the day. The adjutant

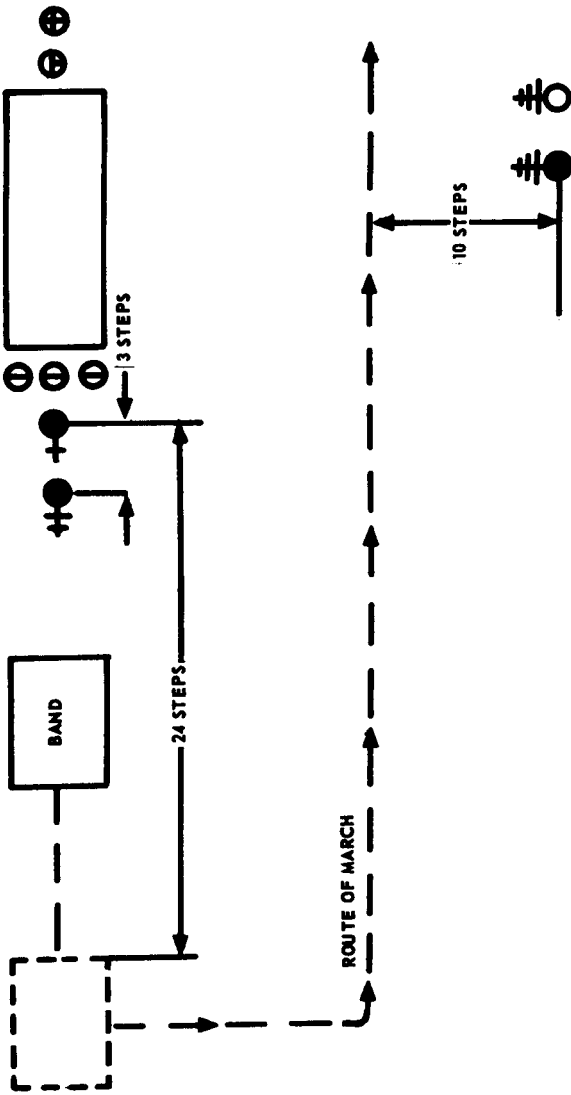

Figure 13. March in review, one platoon.

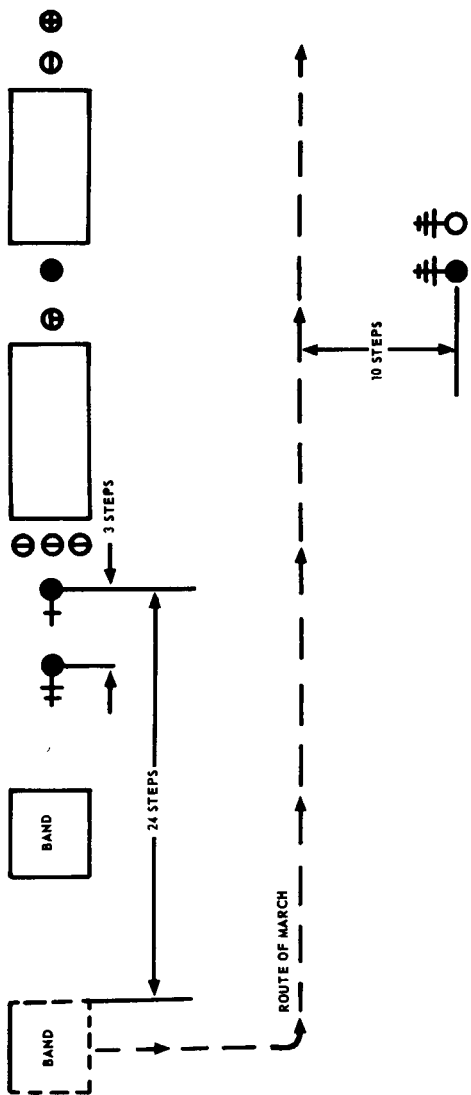

Figure 14. March in review, two platoons.

and commander of the guard salute with the first platoon; the assistant commander of the guard and the sergeant major salute with the second platoon.

e. When the guard is marching in review, the officers of the day stand at attention.

(1) The new officer of the day returns the salutes of the adjutant and the commander of the guard. He salutes only once because of the adjutant and the commander of the guard salute together.

(2) When there are two platoons, he does not return the salute of the assistant commander of the guard.

f. After the band passes the officer of the day, it turns out of column to the left and places itself in front of and facing the officer of the day, 18 steps from where the left flank of the guard passes. It continues to play until the guard leaves the parade ground.

g. The adjutant steps out of column and halts when he is 25 steps beyond the officer of the day. The sergeant major steps out of column and halts abreast of the adjutant and three steps to the left. The adjutant and the sergeant major then face each other, salute, and leave.

h. The commander of the guard marches the guard to the guardhouse without changing his position in the formation.

i. If the guard consists of two platoons, the commander of the guard halts it and forms it into one platoon. The assistant commander of the guard marches three steps to the rear centered on the guard. The assistant sergeant of the guard marches

at normal interval to the left of the assistant commander of the guard.

j. The officers of the day face each other and salute. The old officer of the day gives his orders to the new officer of the day.

66. Formation of the New and Old Guard at the Guardhouse

a. The old guard is formed at the guardhouse as prescribed in paragraph 45 (1, fig 15). (If field music has been authorized, the band forms three steps to the right of the old guard. The band of the new guard forms three steps to the right of the new guard (2, fig 15).)

b. Relieving the old guard at the guardhouse is in accordance with paragraphs 44 through 48.

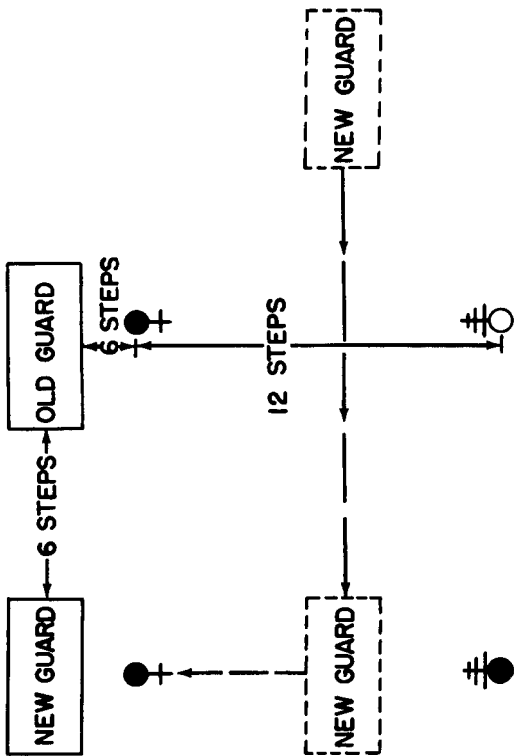

FOR SYMBOLS, SEE FIGURE 19

Figure 15. Formation of guards.

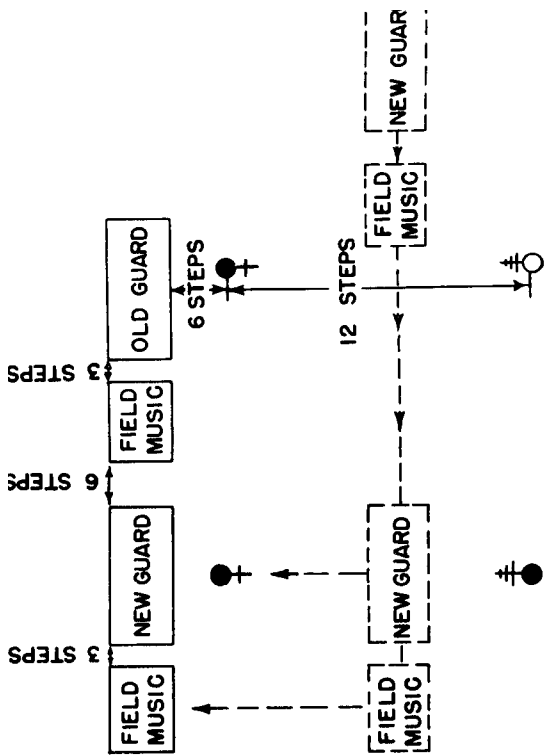

FOR SYMBOLS, SEE FIGURE 19

Fig 15—Continued.

CHAPTER 7

SPECIAL GUARDS

Section I. GENERAL

67. When Detailed

Special guards are detailed when it is impractical to use members of the main guard to guard property or an area. Ordinarily they are governed by the same general principles as the main guard. Special guards follow safety procedures outlined in appendix D.

68. Purpose

Special guards protect vehicles, buildings, equipment, supplies, and other property not protected by the main guard. They enforce special regulations in regard to parks or other property being guarded.

Section II. PARK GUARDS

69. General

Motor parks and tank parks are usually guarded by elements of the main guard. When this is impractical, special park guards are posted.

70. Duties

a. Neither the noncommissioned officer nor members of the park absent themselves from the vicinity of the park unless so ordered.

b. Park guards are not employed for police and fatigue duties at the park except in an emergency.

71. Control of Park Guards

Park guards are under the immediate control of their commanders.

72. Noncommissioned Officers of the Park Guard

a. The noncommissioned officer receives orders from his company commander. When relieved, he turns over all orders to his successor. He instructs his guards in their general and special duties, including safety procedures; exercises general supervision over his entire guard; insures that the guardroom is orderly and clean; and checks the motor vehicles, equipment, and property which he is to protect. Immediately upon going on duty he inspects the area for fire hazards and insures that keys are in vehicles so that they may be moved in case of fire. Before relieving his predecessor, the noncommissioned officer examines all locks, windows, and doors; if any are found insecure, he reports that fact to his company commander when reporting for orders. He personally posts and relieves each guard, taking care to verify the property responsibility of the guard who comes off post. He sees that the guard who goes on post knows the property for which he is responsible.

b. All vehicle returning to the motor park are reported to the noncommissioned officer of the park guard so that he may have knowledge of his added responsibility. He notifies the guard on post of any

changes in the number of vehicles.

c. Other duties of the noncommissioned officer of the park guard include—

(1) Promptly reporting to the company commander any unusual occurrence and any abuse of vehicles or property.

(2) Answering guard calls promptly.

(3) In case of fire, insuring that all firefighting measures, as outlined in paragraph 73, are promptly carried out.

(4) Permitting no vehicles or equipment to be taken from the park except by proper authority.

(5) Designating another member of the guard to take charge and assume responsibility for the post whenever it becomes necessary for him to leave the post.

73. Park Guards

a. Park guards are governed by the regulations for guards on main guard duty.

b. They receive orders only from the commanding officer, the park commander (the officer of the day and officers and noncommissioned officers of the guard when the guard is part of the main guard), and the noncommissioned officer of the park guard.

c. In the field or when so directed by proper authority, the guard, upon being posted, verifies the number of motor vehicles and/or equipment for which he is responsible, and, upon being relieved, gives that number to his successor.

d. In case of fire, the guard sounds the alarm as prescribed in his special orders. Upon sounding the alarm the guard takes such action as is deemed necessary to prevent the spreading of the fire.

Section III. OTHER SPECIAL GUARDS

74. General

Train guards, boat guards, and other guards are detailed as special guards when it is impractical for the main guard to guard the areas or property involved.

75. Duties

The duties of special guards are prescribed by the commanding officer to fit the specific needs.

76. Civilian Guards

Civilian guards are used when authorized by proper authority. They receive their orders and perform their duties as the installation commander may direct.

PART THREE
EXTERIOR GUARD
CHAPTER 8
FUNCTIONS OF THE EXTERIOR GUARD

77. General

Exterior guard is a term used in this manual to classify those guards outside of a military installation, guards in a combat area, guards in hostile or unfriendly territory, and guards (located anywhere) who have to perform their duties in such a manner that the general orders prescribed for interior guard are not applicable or practicable. The conduct and actions of exterior guards are limited only by the desires and instructions of the commanders and small unit leaders and by the training and initiative of the guards themselves. This manual is not intended to limit or dictate the actions of exterior guards but to familiarize the individual soldier with some of the responsibilities and actions of exterior guards. The situation and mission will be the deciding factor when the commander plans for the security of his unit and the actions of his exterior guards.

78. Composition

The composition of an exterior guard is in no way related to that of an interior guard. No commanders

are detailed for that specific duty. The guards are appointed or selected from small units and function under the control and supervision of the small unit leaders (chain of command). The actions and responsibilities of the guards are prescribed by instructions from their leaders, SOPs, and by appropriate field manuals.

79. Responsibilities

A unit must be protected at all times from surprise. Exterior guards are utilized to protect a unit from surprise and to give the unit time to prepare to counter any threat. Guards must be alert for surprise by ground, airborne, and air attacks; to provide early warning of chemical, biological, radiological (CBR) attack or contamination; and to protect supplies and supply installations. If the unit is moving, security may vary from observation to the use of security patrols. During short halts, guards, small security detachments, and forward patrols are used to provide all-round security. For stationary positions in combat or hostile areas, unit commanders use exterior guards to establish a surveillance system to operate day and night throughout the unit area. The commander may use guards, listening posts, observation posts, patrols, aerial observers, and any other available means. The guards may have any number of special devices to assist them in performing their duties. These may include CBR detection devices, electronic detection devices, infrared or other night vision devices, trip flares and antipersonnel mines, noisemaking devices

or any other device to provide early warning to the guard and unit.

80. Patrols

Patrols may be used to cover an area not otherwise under surveillance or gaps between units. To avoid establishing a pattern of operation, these patrols operate at irregular intervals over a variety of routes.

81. Communications

All exterior guards must have an adequate communications system. Special orders or instructions will govern the type of communications. These may be radio, wire, arm-and-hand signals, sounds, or any method specified by the commander or leaders.

82. Areas of Unconventional Operation

Providing adequate and effective guards in areas threatened by a guerrilla force is probably the most difficult task to accomplish in unconventional operations. To increase their effectiveness against guerrillas, all soldiers must be trained in tactics to be used against guerrilla forces. All members of the unit must be thoroughly briefed on known or suspected guerrilla forces. The commanders and guards must use all combat security measures when operating in areas threatened by guerrilla forces. Guards must be particularly alert when in seemingly safe areas, especially when in friendly rear areas. The guerrilla is usually a highly motivated and an able fighter whose actions are characterized by surprise, rapid movement, deception, secrecy, and stealth.

This demands commanders and leaders to exercise methodical supervision and checks on the exterior guard and overall security discipline. The routine means of security are altered frequently to prevent guerrilla forces from obtaining detailed and accurate information about the composition, habits, and location of the exterior guards. In this environment two or more guards should be placed at each post so that one guard provides security for the other when challenging.

83. Tour of Duty

The tour of duty for exterior guards may not be the same as suggested for interior guards. Normally no guardhouse is used; the guards perform their duties and also rest at the same location. When practical, guards operate in pairs or larger group and rotate the watch and rest periods among themselves to insure that the required number of guards are alert at all times. If means are available, personal contact may be made with the guard at irregular intervals. This contact may be made by other guards, patrols, or unit leaders.

84. Countersigns—Challenge and Password

The guards must know and properly use the challenge and password (chap 9). The guard should remain concealed and in a “ready” position at all times when challenging (app F). The regular countersign is used within friendly areas. When outside friendly areas (e.g., on patrol) a different challenge and password should be used. In all cases

when operating outside friendly areas, a means or recognition must be established and properly used.

85. Use of the Countersign

a. A guard should never allow an unidentified person to approach too close to his position. This is important at night and during other periods of poor visibility. Special instructions will be given the guards on the use of the challenge and password (app F). Normally, the challenge and password are always used in friendly rear areas. A guard in a forward position may be instructed to challenge, avoid, or shoot persons near his post. Normally, when the guard is instructed to fire without challenging, all friendly forces have been instructed to remain concealed in their positions and any movement is assumed to be enemy.

b. A guard must be extremely cautious at all times (day and night) about revealing the *challenge and password*. Never use these words unless the unidentified person first exposes himself to view, thereby indicating he is friendly by allowing the guard an opportunity to fire at him. An enemy probably would not expose himself at any time, but would try to learn the *challenge and password* in order to pass through your lines at another point (app F). For example:

(1) An unidentified person approaches your post and calls “friendly party,” or “friend,” but does not come into view.

(2) If you call “Halt!” and then give the challenge, “Boston”, the enemy will simply fade away and go to the next outpost.

(3) At the second outpost the enemy will, when halted, called out “Boston,” hoping to confuse the guard and get him to say the password, “Beans.”

(4) Again, the enemy will slip away, armed with the challenge and password, ready to approach a third outpost where he may be passed through the lines.

86. Challenging Unidentified Persons

a. To challenge unidentified personnel, the guard will call (app F) “Halt!” clearly and just loud enough to be distinctly understood by the challenged party. Keep the party covered without exposing yourself. When he halts, ask in a low, clear voice, “Who is there?” He should reply in a low, clear voice giving the answer which best identifies him self. For example, “Sergeant Black, first squad,” or “Friendly patrol leader.” You then say, “Advance, Sergeant Black, to be recognized,” or “Advance, friendly patrol leader, to be recognized.” Always advance persons by the name with which they identified themselves. This insures that only *that* person advances toward your position. Continue to keep him covered without exposing yourself and halt him again when he is close enough to be identified. If possible, never advance a person closer than 2 meters to your position. In a low, clear voice give him the challenge, for example, “Rainbow.” He should answer with the password, for example, “Archer.” If you are not completely satisfied, question him further. Ask only questions a friendly person would be likely to know.

b. Other men with the challenged person, such as members of a patrol, must be identified. This can be done in one of two ways. Your commander will prescribe the method for you to use.

(1) The leader can vouch for the others and pass them to the flank of your position. This method reduces movement and noise at your position, and helps prevent revealing your location to the enemy.

(2) The leader, or his representative, can identify each man as he passes, notifying you when the last man has passed.

CHAPTER 9

COUNTERSIGNS AND PAROLE WORDS

87. General

The commanding officer (para 4 *a*) directs the use of the countersign and parole word.

a. The *countersign* is used in combat and, when necessary, in garrison.

b. The *parole* (word) is used to check on the countersign when inspecting guards.

c. Any person in time of war who discloses the parole word or countersign to any person not entitled to receive it, shall be punished by death or such other punishment as a court-martial may direct (Article 101, Uniform Code of Military Justice).

88. By Whom Authorized

If a countersign and parole word are prescribed, they are devised by the highest headquarters within a zone or area. This authority (app F) may be delegated to subordinate units so they can designate a countersign or parole immediately, if it becomes necessary; however, these units notify higher headquarters of such action without delay.

89. Selecting Countersigns--Challenge and Password

a. The choice of words or sounds is made with care. Words are selected that are difficult for the

enemy to pronounce and do not indicate the expected answer. When sounds are selected for use they should be distinctive and similar to those normally heard in the locality.

b. The use of the countersign is rigidly controlled and the initiative to use it rests with the challenger (guard). Mutual identification is essential; therefore, the person challenged should not give the password if he fails to recognize the challenge. The challenger (guard) will use only the challenge, never the password, except as prescribed in paragraph 92.

c. Positive identification by the guard of all persons claiming authority to pass is the main consideration. Persons whose sole means of identification is the password are not allowed to pass. If there is a reasonable doubt of the challenged person's authority to pass, even if he gives the password, he apprehended and turned over to the commander on the relief for further investigation.

90. Using Countersigns

When a challenge and password are prescribed, the challenge is given by the guard after the person is advanced to be recognized. The password is given by the challenged person. The challenge and password are given in a low tone to prevent them from being overheard by others. For example, a guard at an ammunition dump observes a group approaching his post. While the group is far enough away (for the guard to take effective measures should the group rush him) he calls "Halt! Who is there?" After receiving an answer (such as "Sergeant

Black, Delta Company”) indicating the group is friendly and that it may be authorized to pass, the guard says, “Advance, Sergeant Black, to be recognized.” When Sergeant Black reaches a point where the challenge, spoken in a low tone, can be heard only by Sergeant Black, the guard again says, “Halt!” Then he gives the challenge in a low tone (e.g. “Rainbow”). After receiving the correct password from Sergeant Black (e.g. “Archer”) and otherwise satisfying himself that Sergeant Black is authorized to pass, the guard says, “Advance, Sergeant Black.” The guard then tells Sergeant Black to bring up his men and identify them as they pass (app F).

91. Parole Words

The commanding officer directs the use of a parole word. *It is a secret word imparted only to those persons entitled to inspect the guard and to commanders and members of the guard.* It is used as a check on the countersign.

92. Using Parole Words

a. The parole word is used by authorized persons to inspect the guards. When the inspector gives a guard the parole word, the guard gives the inspector *both parts* (the *challenge* and the *password*) of the *countersign*. *The guard does not use the password at any other time.* The parole word may be used before or after the hours of challenging; the inspector gives the parole word when he is close enough to prevent it from being overheard by unauthorized persons. Upon hearing the parole word, the guard

knows that he is being inspected by an authorize person. The guard then repeats both parts of the countersign (challenge and password).

b. When used during the hours of challenging, the inspector does not give the parole word until he is advanced to a position near the guard. After being advanced to be recognized, the inspector would then use the parole word and the guard gives him both parts of the countersign. If the guard challenges the inspector with the first part of the countersign, the inspector answers with the parole word instead of the password. The guard then gives the password to the inspector. If the inspector does not wish to reveal his official capacity while inspecting the guard he gives an answer such as “friend” when halted by the guard. Examples of using the parole word: The countersign is “Rainbow-Archer” and the parole word is “Sunshine.” During daylight hours the officer of the day (or any person authorized to inspect the guard) approaches a guard. The guard salutes the officer at the appropriate time. When the officer of the day is close enough to the guard he gives the parole word by saying “Sunshine” in a low tone to prevent it from being overheard. The guard answers by saying “Rainbow-Archer.” This is to insure that the guard knows both parts of the countersign.

c. If the guard halts the officer of the day during the hours for challenging and receives the reply “friend,” then the guard says, “Advance, friend, to be recognized.” When the officer of the day is close enough to be recognized, the guard again halts him. The officer of the day then says, “Sunshine.” The

guard answers “Rainbow-Archer.” If the guard challenges the officer of the day with the *challenge* he says, “Halt, Rainbow.” The officer of the day answers, “Sunshine,” giving the parole word instead of the password. The guard then answers, “Archer.”

APPENDIX A

REFERENCES

- AR 190-2 Installation Confinement Facilities.
AR 190-4 Uniform Treatment of Military Prisoners.
AR 210-10 Administration.
AR 220-45 Duty Rosters.
AR 220-90 Army Bands.
AR 310-25 Dictionary of United States Army Terms.
AR 600-25 Salutes, Honors, and Visits of Courtesy.
AR 635-212 Discharge-Unfitness and Unsuitability.
AR 840-10 Description and Use of Flags, Guidons, Tabards, and Automobile Plates.
FM 19-5 The Military Policeman.
FM 19-60 Confinement and Correctional Treatment of Military Prisoners.
FM 22-5 Drill and Ceremonies.
Uniform Code of Military Justice; Articles—
7. Apprehension.
9. Imposition of Restraint.
11. Reports and Receiving of Prisoners.
96. Releasing Prisoner Without Proper Authority.
97. Unlawful Detention of Another.
101. Improper Use of Countersign.
113. Misbehavior of Sentinel on Lookout.

APPENDIX B

DETAILS AND ROSTERS

1. Detail of Personnel

The personnel required for the fixed posts of the main guard are detailed daily.

2. Detail of Officers

An officer of the day and an officer of the guard are detailed with each main guard unless the commanding officer considers the guard so small that an officer of the guard is unnecessary. When necessary to efficiently supervise and control the men on a relief, a junior officer of the guard is detailed to assist the officer of the guard.

3. Rosters

a. A roster is a list of individuals or organizations available for a specific duty with a record of the duty each has performed (AR 220-45).

b. For an accurate and equal distribution of guard duty, rosters are kept. The method described herein is one acceptable method of keeping a guard roster. Any method that insures equitable performance of guard duty may be used provided it is not in contradiction of AR 220-45.

c. Whenever possible a single organization should provide the guard. This prevents interference or conflict with unit training programs and provides for maintenance of unit integrity.

d. When a single organization, such as a company, provides the entire guard detail for a day, a guard roster showing only organizations is kept by the

sergeant major and no account is taken of a very small difference in the strength of the companies. However, when the difference in strength of the various companies is large, a roster is kept as follows:

(1) Determine the number of sentinels of the guard that each company would be required to furnish if each were to detail its share of each guard. This number is called the *proportion* for each company. The method for finding this proportion is explained in *f* below. These numbers are entered in the *proportion* column of each company on the roster (fig 16).

(2) Give a minus sign to the proportion number of each company that does not furnish guard for a particular day. Add this number algebraically to the number listed in the credit column for the preceding day. On the day the roster is initiated, enter a negative proportion number in the credit column.

(3) Subtract the proportion for the company providing the guard from the number of men it actually furnished. Give this difference a plus sign and add it algebraically to the number in the credit column for the preceding day.

(a) The company that has the largest minus number in the credit column is usually selected to furnish the next guard; however, the choice of the company that will provide the next guard depends upon the company's administrative load and training schedule.

(b) Rosters for sergeants and relief commanders of the guard provided by a single organization are also determined in this manner.

Guard furnished		A Company			B Company			C Company			D Company			
		Number of Sentinels	Strength	Proportion	Credit	Strength	Proportion	Credit	Strength	Proportion	Credit	Strength	Proportion	Credit
Jan. 1	A	13	50	4.17	+8.83	40	3.33	-3.33	35	2.92	-2.92	31	2.58	-2.58
Jan. 2	A	13	50	4.17	+17.66	40	3.33	-6.66	35	2.92	-5.84	31	2.58	-5.16
Jan. 3	B	15	50	5.00	+12.66	40	4.00	+4.34	30	3.00	-8.84	30	3.00	-8.16
Jan. 4	B	15	50	5.00	+7.66	40	4.00	+15.34	30	3.00	-11.84	30	3.00	-11.16
Jan. 5	C	15	50	5.00	+2.66	40	4.00	+11.34	30	3.00	+1.16	30	3.00	-14.16
Jan. 6	D	15	50	5.00	-2.34	40	4.00	+7.34	30	3.00	-2.84	30	3.00	-2.16
Jan. 7	A	15	50	5.00	+7.66	40	4.00	+3.34	30	3.00	-5.84	30	3.00	-5.16
Jan. 8	C	15	50	5.00	+2.66	40	4.00	-.66	30	3.00	+6.16	30	3.00	-8.16
Jan. 9	D	15	50	5.00	-2.34	40	4.00	-4.66	30	3.00	+3.16	30	3.00	+3.84
Jan. 10	B	15	50	5.00	-7.34	40	4.00	+6.34	30	3.00	+1.16	30	3.00	+.84
Jan. 11	A	15	50	5.00	+2.66	40	4.00	+2.34	30	3.00	-2.84	30	3.00	-2.16
Jan. 12	A	15	50	5.00	+12.66	40	4.00	-1.66	30	3.00	-5.84	30	3.00	-5.16
Jan. 13	C	15	50	5.00	+7.66	40	4.00	-5.66	30	3.00	+6.16	30	3.00	-8.16
Jan. 14	D	15	50	5.00	+2.66	40	4.00	-9.66	30	3.00	+3.16	30	3.00	+3.84
Jan. 15	B	15	50	5.00	-2.34	40	4.00	+1.34	30	3.00	+1.16	30	3.00	+3.84

Figure 16. Roster for privates of the guard when single organization furnishes the guard.

e. When several organizations provide personnel for each guard—

(1) The adjutant keeps a roster of all officers of the day and officers of the guard by name.

(2) The sergeant major keeps a roster of all sergeants of the guard, relief commanders, and privates of the guard by number or organization.

(3) The first sergeants keep a roster of all sergeants of the guard, relief commanders, and sentinels of the guard by name.

f. The methods of determining the number of sentinels of the guard that are due from several companies is shown in figure 17. This figure shows the method used on the first and second days after setting up a guard system. The method used for the second day is used on each succeeding day until the number of organizations furnishing details changes

A discussion of the methods used follows:

(1) Take a number of personnel eligible for sentinel duty in each company from its morning report for the day before that on which the tour of duty is to begin. Deduct details for detached service of over 24 hours that are made after the morning report is received. The total is the actual number of personnel available for sentinel duty. Enter this figure in the *strength* column for each company (fig 17).

(2) Then multiply the total guard detail needed by the strength of the company and divide the result by the total strength of the command. This gives the proportion for that company. Carry this proportion out to 2 decimal places. This is done for each

First Day

Company		Strength of Sentinels of guard required (including 3 for park guard)	Total strength	Proportion	Detail	Credit
A—25	×	14	+130	2.69	3	+ .31
B—35	×	14	+130	3.77	4	+ .23
C—36	×	14	+130	3.88	4	+ .12
D—34	×	14	+130	3.66	3	— .66
				11	14	
						130

Second Day

Comp.		Strength of Sentinels of guard required (including 3 for park guard)	Total strength	First proportion	Credits brought forward	Final proportion	Detail	Credit
A—30	×	14	+130	3.23	+ .31	2.92	3	+ .08
B—30	×	14	+130	3.23	+ .23	3.00	3	.00
C—34	×	14	+130	3.66	+ .12	3.54	4	+ .46
D—36	×	14	+130	3.88	— .66	4.54	4	— .54
						12	14	
								130

Figure 17. Method of determining daily proportional number of sentinels of the guard from several organizations.

company. Enter this figure in the proportion column for each company (fig 17).

(3) Add the *whole* numbers in the proportion column together. If the total is less than the total guard detail needed, add one to the whole number

in the proportion that has the largest fraction, and so on for each company until the required total for the guard detail is obtained. Enter these whole numbers in the *detail* for each company (fig 17).

(4) Enter in the *credit* column the difference between the exact proportion (proportion column) and the number detailed (detail column) from each company.

(5) Bring the credits forward to the next day and add them to or subtract them from the first proportion. If the credit brought forward has a plus sign, subtract it from the first proportion. This is done because the proportion of the guard for the next day is to be reduced by the credited amount. If the credit has a minus sign, add it to the first proportion; the proportion is to be increased by this amount. This gives a final proportion which is used in figuring the detail and credit columns of succeeding days.

(6) A typical roster for sentinels of the guard, using this information, is shown in figure 18.

(7) The above methods are used to determine the number of sergeants of the guard and relief commanders and a similar roster is prepared for each.

g. When organizations provide their own park guards, credit is given each organization for the number of enlisted men detailed as though they had been detailed for main guard.

h. Other special guards are credited as the commanding officer directs.

Date:	1 Jan.	2 Jan.	3 Jan.
Guard required:	14	14	14
A Company:			
Strength	25	30	30
First proportion	2.69	3.23	3.23
Final proportion		2.92	3.15
Detail	3	3	3
Credit	+ .31	+ .08	- .15
B Company:			
Strength	35	30	30
First proportion	3.77	3.23	3.23
Final proportion		3.00	3.23
Detail	4	3	3
Credit	+ .23	.00	- .23
Company:			
Strength	36	34	34
First proportion	3.88	3.66	3.66
Final proportion		3.54	3.20
Detail	4	4	3
Credit	+ .12	+ .46	- .20
D Company:			
Strength	34	36	36
First proportion	3.66	3.88	3.88
Final proportion		4.54	4.42
Detail	3	4	5
Credit	- .66	- .54	+ .58

Figure 18. Roster for sentinels of the guard when several organizations provide the guard.

APPENDIX C

LEGEND OF SYMBOLS









-  OFFICER OF THE DAY
-  OLD OFFICER OF THE DAY
-  ADJUTANT
-  COMMANDER OF THE GUARD
-  ASSISTANT COMMANDER OF THE GUARD
-  SERGEANT MAJOR
-  SERGEANT OF THE GUARD
-  ASSISTANT SERGEANT OF THE GUARD
-  COMMANDER OF THE RELIEF

Figure 19. Symbols.

APPENDIX D

SAFETY REGULATIONS

Section I. SAFETY PROCEDURES

1. General

All personnel armed with their individual weapon must be qualified with the weapon, including the safety regulations for the weapon. Weapons are not carried with cartridges in the chamber or receiver except on orders from the commanding officer. When loaded, weapons are carried locked.

2. Retreat Guns

Safety regulations for firing retreat guns are published by installation commanders and depend on the type of gun used. These regulations are to be understood and complied with by all personnel detailed to fire the retreat gun.

Section II. SAFETY RESPONSIBILITY

3. Post Commander

Installation commanders insure that any new regulations about safety as it applies to guard are made available to the guard immediately.

4. Company Commander

Company commanders are responsible for the weapons qualification, familiarization, and instruction on

applicable safety regulations of all personnel in their companies. Any man assigned to guard duty who is not qualified or familiar with the weapon he is to carry is replaced at once. He is not assigned to guard duty until he becomes qualified or familiar with the weapon used on guard, or until he can be equipped with a weapon with which he is already qualified. Qualification pertains to individual weapons. Personnel armed with weapons other than their individual weapon (shotguns (FM 19-60), riot clubs (FM 19-5)) should receive training on that weapon prior to going on guard.

5. Officer of the Day

It is the responsibility of the officer of the day to see that all violations of safety regulations that come to his attention are reported to the offender's company commander. If the violation is serious, he reports it to the commanding officer, who takes appropriate action.

6. Commander of the Guard

The commander of the guard insures that members of his guard observe safety regulations. In the event of a violation, he reports the incident to the officer of the day for appropriate action. The commander of the guard is responsible for accountability of live ammunition utilized by the guards during his tour of duty.

7. Sergeant of the Guard

The sergeant of the guard is responsible for the conduct of the guard and reports all violations of

safety regulations to the commander of the guard for appropriate action. Whenever possible, he is present at guard formations which involve loading and unloading weapons. He makes sure that all safety regulations are observed.

8. Commander of the Relief

The relief commander of the guard is responsible that safety precautions are observed by his relief. He reports any man in his relief who violates safety regulations, and if the violation is serious, requests the sergeant of the guard to replace the offender. The relief commander will personally supervise the loading, unloading, and clearing of weapons by guards being posted and relieved when live ammunition is used.

9. Sentinels of the Guard

Sentinels on guard observe all safety regulations. If the sentinel has any doubt about any of these regulations he requests instructions from the commander of his relief prior to being posted.

APPENDIX E

PRISONERS AND PRISONER GUARDS

1. Rules Governing Prisoners

AR 190-2, Installation Confinement Facilities, and AR 190-4, Uniform Treatment of Military Prisoners, prescribe uniform procedures for the administration, treatment, and disposition of military persons confined at Army installations. The correctional officer is responsible to the provost marshal who in turn is responsible to the installation commander on all matters relating to the administration and operation of a correctional facility.

2. Confinement and Release of Prisoners

a. A prisoner, from the first day of confinement until his sentence is announced, is held in confinement by authority of a properly executed confinement order. After being sentenced by a court, the prisoner is held in confinement by the convening authority who reviews the court proceedings.

b. All prisoners are released from confinement only by an order of the proper authority.

3. Custodial Personnel

a. The provost sergeant is the senior enlisted assistant to the correctional officer.

b. The correctional officer either operationally controls or commands all custodial personnel as-

signed and guard personnel for duty in the correctional facility and is the commanding officer of personnel assigned to the correctional holding detachment. He is responsible for making certain that all custodial personnel assigned as work supervisors are properly armed and instructed in the use of their weapons (when weapons are required), know their general and special orders, and are instructed in their duties.

c. Personnel from the installation units may be used during an emergency to augment the correctional facility custodial personnel. Personnel from other units on the installation will not be detailed as work supervisors.

4. Prisoner Guards

a. A prisoner guard is detailed for the particular duty of guarding prisoners who are taken out of a correctional facility for work or other purposes. Prisoner guards should be detailed for not less than one month. The number of men detailed on prisoner guard is kept to the minimum. Normally, prisoner guards are not part of the interior guard.

b. A part of the personnel from the main guard may be used in an emergency to augment the stockade custodial personnel.

5. Guards on Duty at Confinement Facilities

a. A prisoner guard actively assigned to guarding prisoners is considered on post.

b. In the event of an attempted mass breakout from confinement, riot, or other general disorder,

a prisoner guard takes immediate action, using that force necessary to restore order or prevent escape. The force used, in any case, is limited to that which is reasonable and necessary to enforce regulations and to control prisoners. For priorities of force at an Army confinement facility, see AR 190-4.

c. Caution and good judgment will control the use of firearms in preventing the escape of a prisoner. In certain cases, as determined by the correctional officer, different classifications of prisoners will require only unarmed supervision; however, when firearms are used by a prisoner guard, they will be used when no other reasonable means of preventing an escape is considered effective, and realizing that firing to prevent an escape is justifiable only as a last resort. If a prisoner attempts to escape the guard will call HALT twice. If the prisoner fails to halt, and if there is no other effective means for preventing his escape, the guard directs shots at the prisoner which are aimed to disable rather than to kill. Extreme care must be taken to avoid hitting innocent bystanders.

d. A prisoner guard placed over prisoners should receive specific instructions from the confinement officer or provost sergeant. Guards are responsible for making sure that the work of the prisoners is performed satisfactorily.

e. They should not allow anyone to come between them and the members of their details or to talk, or give any object to prisoners.

f. A prisoner guard, placed over prisoners, strictly enforces the rules for the conduct and control of prisoners in accordance with the instructions received or the local policies.

g. Prisoners, except installation parolees and those assigned to military retraining units, are denied the privilege of the military salute.

6. Temporary Release of Prisoners to Unit Guards

Units will normally provide guards when a temporary release of a prisoner of that unit is necessary for routine administration (i.e., appointment for physical examination and mental evaluation or for administrative elimination under provisions of AR 635-212, appointment with JAG personnel, purchase of required clothing, etc.).

APPENDIX F
DETAILS OF AGREEMENT FROM
STANAG NO. 2042 (2d edition)
AND CENTO STANAG NO. 2042

(Details of Agreement of CENTO STANAG No. 2042 are identical with Details of Agreement of NATO STANAG No. 2042 (2d edition). Therefore, CENTO STANAG No. 2042 is not reproduced.)

NATO UNCLASSIFIED

Agreed English/French Texts. STANAG 2042
(Edition No. 2)

DETAILS OF AGREEMENT (DofA)
METHOD OF CHALLENGING BY GUARDS
AND SENTRIES

AGREEMENT

1. It is agreed that the NATO Armed Forces are to follow the method of challenging by guards and sentries detailed below.

DEFINITIONS

2. These definitions are taken from AAP-6, "The NATO Glossary of Military Terms and Definitions in English and French" where applicable:

NATO UNCLASSIFIED

NATO UNCLASSIFIED

- a. Challenge. Any process carried out by one unit or person with the object of ascertaining the friendly or hostile character or identity of another.
- b. Reply. An answer to a challenge.
- c. Password. A secret word or distinctive sound used to reply to a challenge.
- d. Countersign. A secret challenge and its reply, e.g., NUTS = challenge, WINE = password or reply.

GENERAL

3. The conduct of the individual sentry is to be prescribed by the authorities of his own force and may be varied in accordance with operational or other special requirements.
4. Confusing or misleading replies to a challenge are prohibited.
5. The countersign is normally prescribed by the highest authority within a zone or area. This power may be delegated, but higher authority must be informed without delay when such power is exercised by a subordinate.
6. When forces of two or more nations are in the same area, the countersign should be selected from words which can be readily pronounced by the forces concerned.

NATO UNCLASSIFIED

NATO UNCLASSIFIED

PROCEDURE FOR CHALLENGING
AND REPLYING

7.

Action by Sentry	Action by Person or Group Challenged
a. "HALT! WHO IS (or GOES) THERE?"	a. Halts and gives any reply which indicates the person or group is authorized to pass, e.g. "FRIEND", "ALLY", "CORPORAL OF THE GUARD", etc.
b. "ADVANCE (ONE) AND BE RECOGNIZED".	b. Person (or group leader) advances without replying.
"HALT!" (When unknown has approached sufficiently for sentry to recognize him or to give challenge)	c. Person halts until recognized by sentry.
d. Challenge (if any) is given in a low tone.	d. Reply or password is given in a low tone.
e. "ADVANCE AN-OTHER ONE (or REMAINDER) AND BE RECOGNIZED". (Sentry calls forward remainder one by one or as a group, as the situation or his orders demand.)	e. Second unknown (or remainder of group) advances at order of sentry to be recognized. Group leader, or person designated by leader must remain with sentry to assist in identifying remainder of group.

NATO UNCLASSIFIED

NATO UNCLASSIFIED

FIRING BY SENTRIES

8. The circumstances under which a sentry is to be instructed to fire on persons or groups failing to heed a challenge is left to national authorities and must, necessarily, vary depending upon the particular situation and the laws of the countries concerned.

IMPLEMENTATION OF THE AGREEMENT

9. This STANAG will be considered to have been implemented when the necessary orders/instructions to adopt the method described in this Agreement have been issued to the forces concerned.

NATO UNCLASSIFIED

INDEX

	Paragraph	Page
Color guards -----	23	5-11
Commanding officer -----	4	2-1
Commander of the guard -----	4	2-1
Correctional officer -----	4	2-1
Countersign :		
Selection -----	89	9-1
Use -----	90	9-2
Who authorizes -----	88	9-1
Exterior guard :		
Challenging -----	86	8-6
Communications -----	81	8-3
Composition -----	78	8-1
Countersigns -----	84-85	8-4
Patrols -----	80	8-3
Responsibilities -----	79	8-2
Tour of duty -----	83	8-4
Unconventional operations -----	82	8-3
Field officer of the day -----	4	2-1
Fixed post system -----	28	5-12
General orders, meaning -----	10	4-2
Guard :		
Exterior -----	6	3-1
Interior -----	6	3-1
Guard inspection -----	12	4-11
Guard mounting :		
Formal -----	52-66	6-26
Forming -----	82	6-1
Informal -----	37-43	6-5
Inspection -----	33-36	6-1
Posting reliefs -----	49-51	6-17
Relieving old guard -----	44-48	6-12
Requirements -----	31	6-1
Guard mount, formal :		
Adjutant's report -----	64	6-34
Alining guard -----	56	6-28
Assembly of band -----	53	6-26

	Paragraph	Page
Assembly of guard -----	54	6-26
Closing ranks -----	62	6-33
Inspection of guard -----	61	6-33
Marching in review -----	65	6-34
Marching to center -----	59	6-31
March to parade ground -----	55	6-27
Sergeant major's report -----	58	6-29
Sergeant of guard report -----	57	6-28
Returning to posts -----	60	6-31
Sound off -----	63	6-33
Guard mount, informal :		
Assembly -----	38	6-5
Formation -----	39	6-5
Inspection -----	43	6-10
Marching to center -----	41	6-6
Reporting to officer of day -----	40	6-6
Return to posts -----	42	6-8
Guard mount, inspection :		
Assembly -----	34	6-2
Formation -----	35	6-2
Preparation -----	36	6-3
Guard mount, posting relief :		
Posting guards -----	50	6-17
Posting relief -----	51	6-24
Guard mount, relief :		
Arrival at guardhouse -----	44	6-12
Disposition, old, new guards -----	48	6-16
Formation, old, new guards -----	45	6-13
Presenting guards to officer of day -----	47	6-15
Presenting old, new guards -----	46	6-15
Guard post -----	4	2-1
Inspections -----	33, 43,	6-1, 6-10,
	61	6-33
Main guard :		
Arms, equipment -----	15	5-1
Composition -----	13	5-1
Personnel duties :		
Color guards -----	23	5-11

	Paragraph	Page
Commander of guard -----	19	5-5
Commanding officer -----	16	5-2
Field officer of day -----	17	5-3
Relief commander -----	21	5-9
Sergeant of guard -----	20	5-7
Officer of the day -----	4	2-1
Orders :		
General -----	9	4-1
Special -----	11	4-10
Parole words -----	91-92	9-3
Patrol system :		
Personnel -----	25	5-12
Reliefs -----	26	5-12
Reserve -----	27	5-12
Relief commanders -----	4	2-1
Sergeant of the guard -----	4	2-1
Special guards :		
Detailed -----	67	7-1
Other type guards -----	74	7-4
Park guard :		
Control of -----	71	7-2
Duties -----	70	7-1
Guards -----	73	7-3
NCOs -----	72	7-2
Purpose -----	68	7-1
Special orders -----	11	4-10
Stockade -----	4	2-1
Supernumerary -----	4	2-1
Terminology :		
Challenge -----	4	2-1
Commander of the guard -----	4	2-1
Commanding officer -----	4	2-1
Correctional officer -----	4	2-1
Countersign -----	4	2-1
Field officer of the day -----	4	2-1
Fixed post system -----	4	2-1
Guardhouse -----	4	2-1
Guard post -----	4	2-1

	Paragraph	Pa
Guard, sentry, sentinel -----	4	2-1
Main guard -----	4	2-1
Officer of the day -----	4	2-1
Parole (word) -----	4	2-1
Password -----	4	2-1
Relief commanders -----	4	2-1
Sergeant of the guard -----	4	2-1
Stockade -----	4	2-1
Supernumerary -----	4	2-1

By Order of the Secretary of the Army:

W. C. WESTMORELAND,
General, United States Army,
Chief of Staff.

Official:

VERNE L. BOWERS,
Major General, United States Army,
The Adjutant General.

Distribution :

To be distributed in accordance with DA Form
12-11 requirements for Interior Guard Duty.

☆ GPO : 1993 O - 342-421 (80962)

PIN: 023689-001